

Fußrastenanlagen

Rear sets

Kit de commandes reculées

Fußrasten-Adapterplatten mit ABE
Footrest adjuster plates
Adaptateurs de kit de commandes reculées



**Jetzt neu mit ABE.
Kein TÜV mehr nötig!**



Verlegungsmöglichkeiten bei Original-Fußrastenanlagen.
Makes original footrests adjustable.
Possibilité d'ajustement avec les kits commandes reculées d'origines.

► 26 mm – 46 mm
 ▲ max. 25 mm
 ▼ max. 10 mm

Adapterplatten zur Verlegung von Original- oder Lucas-Fußrastenanlagen

- hochfeste Aluminiumprodukte aus CNC-Fertigung
- variable Rastenposition für komfortable Sitzposition
- mehr Bodenfreiheit durch geänderte Fußrastenposition

Can be used with all Lucas footrest assemblies or the original ones

- highly stable CNC manufactured aluminium products
- variable positions to make riding more comfortable
- raises the footrest position for greater ground clearance

Peut être utilisé avec les commandes reculées Lucas ou celles d'origine

- produits en aluminium de très haute précision réalisés en commande numérique
- qui offre une position de conduite plus agréable
- pour adapter la position des repose-pieds par rapport au sol

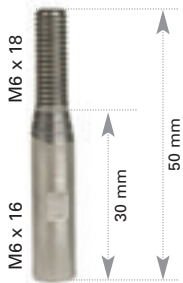

MCF 430

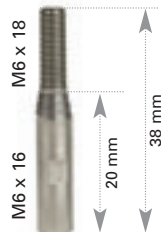

MCF 420

Mehrfach verstellbarer Schalthebel, auch für Umkehrschaltung geeignet.
Adjustable gear lever, also allows reversing the shift pattern.
Lever ajustable de plusieurs façons, indiqué également pour le circuit inversé.



MCF 450

Universal-Schalthebel für den Getriebeausgang

Universal gear change lever
Lever universel pour boîte de vitesses

Schaltstangenverlängerung aus Edelstahl

Extension bracket for shifting rods
Tige d'extension sélecteur

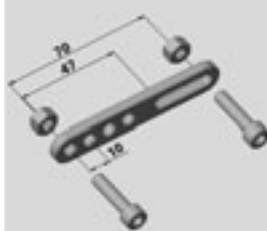

MCF 440

Adapter zur Verlegung von Bremsflüssigkeitsbehältern

Adapter for relocating brake fluid reservoirs
Adaptateur pour la pose du réservoir à liquide de frein



Aprilia

RSV	1000	Mille	ME	98-00	MCF 706-L	MCF 706-R
RSV	1000	Mille	RP	01-03	MCF 706-L	MCF 706-R
RSV	1000	Mille R	RP	01-03	MCF 706-L	MCF 706-R
RSV	1000	Mille SP	RP	01-03	MCF 706-L	MCF 706-R
RSV	1000	R	RR	04-	MCF 707-L	MCF 707-R

Honda

CBR	600	F	PC35	99-	MCF 728-L	MCF 728-R
CBR	600	RR	PC37	03-07	MCF 794-L	MCF 794-R
CBR	900	RR	SC28	92-93	MCF 721-L	MCF 721-R
CBR	900	RR	SC28	94-95	MCF 721-L	MCF 721-R
CBR	900	RR	SC33	96-97	MCF 721-L	MCF 721-R
CBR	900	RR	SC33	98-99	MCF 721-L	MCF 721-R
CBR	900	RR	SC44	00-01	MCF 791-L	MCF 791-R
CBR	954	RR	SC50	02-03	MCF 791-L	MCF 791-R
CBR	1000	RR	SC57	04-07	MCF 794-L	MCF 794-R
VTR	1000	SP1	RC51	00-	MCF 792-L	MCF 792-R

Kawasaki

ZX-6R	600	Ninja	ZX600F	94-97	MCF 730-L	MCF 730-R
ZX-6R	600	Ninja	ZX600G/H	98-02	MCF 738-L	MCF 738-R
ZX-6R	600	RR	ZX600K	03-04	MCF 777-L	MCF 777-R
ZX-6R	600	RR	ZX600C	05-	MCF 771-L	MCF 771-R
ZX-6R	636	Ninja	ZX636A	02	MCF 738-L	MCF 738-R
ZX-6R	636	Ninja	ZX600B	03-04	MCF 777-L	MCF 777-R
ZX-6R	636	Ninja	ZX600C	05-06	MCF 771-L	MCF 771-R
ZX-7R	750	Ninja	ZX750N	96-	MCF 730-L	MCF 730-R
ZX-7R	750	Ninja	ZX750P	96-	MCF 730-L	MCF 730-R
ZXR	750		ZX750J	91-95	MCF 730-L	MCF 730-R
ZXR	750		ZX750L	91-95	MCF 730-L	MCF 730-R
ZXR	750	R	ZX750K	91-92	MCF 730-L	MCF 730-R
ZXR	750	R	ZX750M	93-95	MCF 730-L	MCF 730-R
ZX-9R	900	Ninja	ZX900B	93-97	MCF 730-L	MCF 730-R
ZX-9R	900	Ninja	ZX900C	98	MCF 738-L	MCF 738-R
ZX-9R	900	Ninja	ZX900D	98-99	MCF 738-L	MCF 738-R
ZX-9R	900	Ninja	ZX900E	00-03	MCF 738-L	MCF 738-R
ZX-10R	1000	Ninja	ZX100C	04-05	MCF 779-L	MCF 779-R
ZX-10R	1000	Ninja	ZX100D	06-07	MCF 778-L	MCF 778-R

Suzuki

GSF	600	Bandit	GN77B	94-99	MCF 745-L	MCF 745-R
GSF	600	Bandit	WVA8	00-04	MCF 745-L	MCF 745-R
GSXR	600		AD311	96-03	MCF 741-L	MCF 741-R
GSXR	600		WVB2	04-05	MCF 741-L	MCF 741-R
GSXR	600		WVCE	06-07	MCF 787-L	MCF 787-R
SV	650		AV111	99-02	MCF 741-L	MCF 741-R
SV	650		WVBY	03-	MCF 741-L	MCF 741-R
GSXR	750	W	GR7DB	96-99	MCF 741-L	MCF 741-R
GSXR	750	W	WVBD	00-03	MCF 741-L	MCF 741-R
GSXR	750		WVB3	04-05	MCF 741-L	MCF 741-R
GSXR	750		WVCF	06-07	MCF 787-L	MCF 787-R
GSXR	1000		WVBL	01-02	MCF 741-L	MCF 741-R
GSXR	1000		WVBZ	03-04	MCF 741-L	MCF 741-R
GSXR	1000		WVB6	05-06	MCF 786-L	MCF 786-R
SV	1000		WVBX	03-	MCF 741-L	MCF 741-R
GSXR	1100	W	GU75C	93-97	MCF 743-L	MCF 743-R
GSF	1200	Bandit	GV75A	96-00	MCF 745-L	MCF 745-R
GSF	1200	Bandit	W VA9	01-06	MCF 745-L	MCF 745-R

Triumph

	900	Speed Triple	T509	97-99	MCF 760-L	MCF 760-R
	950	Daytona	T595	97-98	MCF 760-L	MCF 760-R
	955	Daytona i	T595	99-	MCF 760-L	MCF 760-R
	955	Speed Triple		00-	MCF 760-L	MCF 760-R

Yamaha

YZF	600	R6	RJ05	03	MCF 767-L*	MCF 767-R*
YZF	600	R6	RJ09	04-05	MCF 767-L*	MCF 767-R*

* Schaltung außerhalb des Rahmens Gearchange rod outside the frame Connexion en dehors du cadre

Racing Rastenanlagen

Rear sets for racing

Kits de commandes reculées

BLACK EDITION Fußrastenanlagen

- hochwertige Rastenanlagen für ambitionierte Sportfahrer
- mit CNC-gefräste Anlagen, schwarz eloxiert und vormontiert
- individuelle Verstellmöglichkeiten
- Umkehrschaltung ohne großen Aufwand möglich
- superleichte Ausführung ab ca. 700 Gramm
- Racingrasten inkl. Teflonstopfen
- Auslieferung grundsätzlich mit schwarzem Fersenschutz

BLACK EDITION Rear sets

- high-grade foot rest units for ambitious racing drivers
- with CNC-milled units, anodised black and pre-assembled
- individual adjustment options
- reversing shift pattern also possible with no major effort or cost
- extremely light model from approximately 700 grammes
- racing foot rests including Teflon bungs
- delivery always includes black heel guard

BLACK EDITION Kits de commandes reculées

- repose-pieds de qualité supérieure pour les conducteurs sportifs ambitieux
- avec équipements fraisés CNC, anodisés noir et pré-montés
- possibilités de réglage individuelles
- connexion par couplage inversé possible sans grandes difficultés
- modèle ultraléger à partir de 700 grammes
- repose-pieds racing, y compris embouts en téflon
- livraison toujours avec protège-chevilles noir



Mit TÜV-Gutachten, kein Eintrag im Schein oder Brief nötig!



MCF 106 RAC	MCF 463 S	MCF 503 S	MCF 431 S	MCF 406-L	MCF 406-R	MCF 606-L	MCF 606-R	MCF 507
MCF 107 RAC	MCF 463 S	MCF 503 S	MCF 431 S	MCF 407-L	MCF 407-R	MCF 607-L	MCF 606-R	MCF 508
MCF 195 RAC	MCF 465 S	MCF 505 S	MCF 431 S	MCF 495-L	MCF 495-R	MCF 695-L	MCF 695-R	MCF 509
MCF 198 RAC	MCF 468 S	MCF 508 S	MCF 431 S	MCF 498-L	MCF 498-R	MCF 698-L	MCF 698-R	MCF 510
MCF 187 RAC	MCF 465 S	MCF 505 S	MCF 431 S	MCF 487-L	MCF 487-R	MCF 687-L	MCF 687-R	MCF 511
MCF 196 RAC	MCF 466 S	MCF 506 S	MCF 431 S	MCF 496-L	MCF 496-R	MCF 696-L	MCF 696-R	MCF 515
MCF 197 RAC	MCF 467 S	MCF 507 S	MCF 431 S	MCF 497-L	MCF 497-R	MCF 697-L	MCF 697-R	MCF 513
MCF 199 RAC	MCF 469 S	MCF 509 S	MCF 431 S	MCF 499-L	MCF 499-R	MCF 699-L	MCF 699-R	MCF 514



MCF 927 S



MCF 927 R



MCF 928



1 Stück
1 piece
1 pièce

MCF 920 S



MCF 901 S

Fersenschutz, Aluminium
Aluminium ankle guard
Protège-chevilles en aluminium

Fersenschutz, Aluminium
Aluminium ankle guard
Protège-chevilles en aluminium

Fersenschutz, Carbon
Carbon ankle guard
Protège-chevilles en carbon



2 Stück
2 pieces
2 pièces

MCF 905 S

Ersatzraste
Replacement rest
Commande de rechange

1 Stück
1 piece
1 pièce



MCF 431 S

Ersatz-Schaltstangen (Bitte das dazugehörige Modell angeben!)
Replacement shifting rods (Please state the exact type of motorcycle!)
Tiges de commandes sélecteur (Merci de préciser le type exact de la moto!)

Racing



Schalthebel
Gear shift lever
Sélecteur

Bremshebel
Brake lever
Pédale de freins



Farbe
Colour
Couleur

Aprilia					
RSV	1000	Mille	ME/RP	98-03	MCF 106 RAC
RSV	1000		RR	04-	MCF 107 RAC
RSV	1000	Touno	RR	04-	MCF 107 RAC
Honda					
CBR	600		RR	03-	MCF 195 RAC
CBR	1000		RR	04-	MCF 195 RAC
Kawasaki					
ZX-6	600		RR	07-	MCF 198 RAC
Suzuki					
GSXR	600		WVCE	06-	MCF 187 RAC
GSXR	750		WVCF	06-	MCF 187 RAC
GSXR	1000		WVCL	07-	MCF 196 RAC
Triumph					
	675	Daytona	MD	07-	MCF 197 RAC
Yamaha					
YZF	1000	R1	RN19	07-	MCF 199 RAC

Für Top-Rennfahrer wie Barry Veneman entwickelt (Suzuki WM-Team, NL).

Developed for top riders like Barry Venemann (Suzuki Team, NL).

Conseilles par l'équipe Barry Veneman (Suzuki Team, NL).

Fußrastenanlagen mit TÜV
Rear sets
Kits de commandes reculées

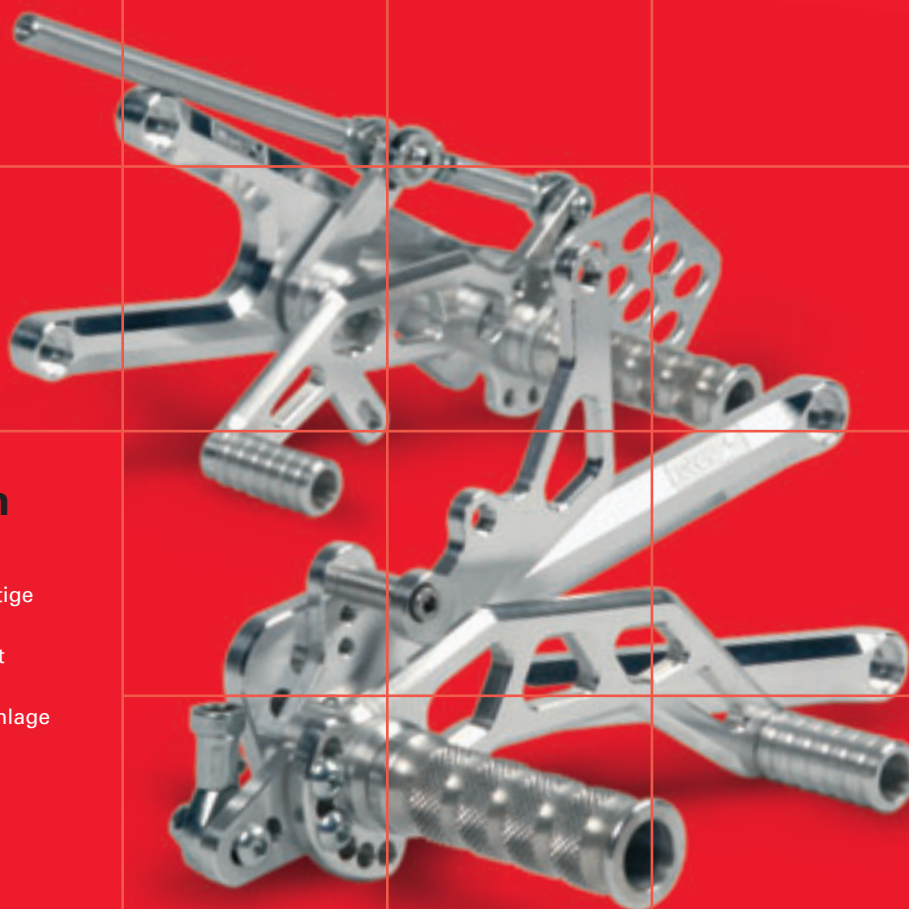

EVOLUTION
Die neue Generation
Fußrastenanlagen

- hochwertige und trotzdem preisgünstige Fußrastenanlage
- mit 6-facher Verstellmöglichkeit direkt auf der Grundplatte
- langfristig löst die Evolution-Rastenanlage alle Classic-Modelle ab

EVOLUTION
The new generation
of footrests

- high quality yet good value footrests
- 6 position adjustable footrest with horizontal and vertical movement
- eventually all classic models will be replaced by the Evolution Footrest

EVOLUTION
La nouvelle génération
de commandes reculées

- très bon rapport qualité/prix pour les commandes reculées qui sont dotées d'une platine offrant
- 6 positions de réglages aussi bien vertical que horizontal (pour être parfaitement adapté à la morphologie du pilote)
- tous les modèles classiques seront remplacés au fur et à mesure par les commandes reculées Evolution

**Mit TÜV-
Gutachten,
kein Eintrag
in Schein oder
Brief nötig!**

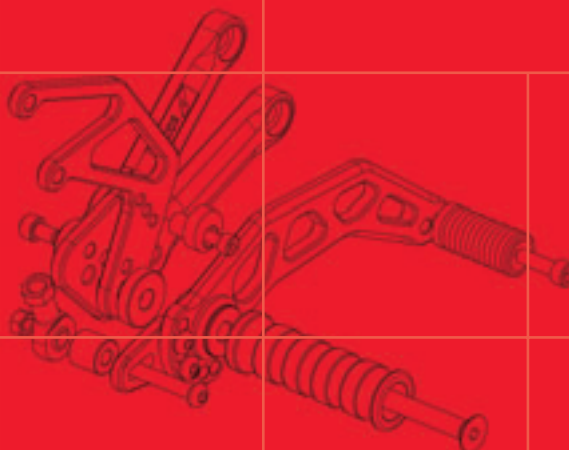

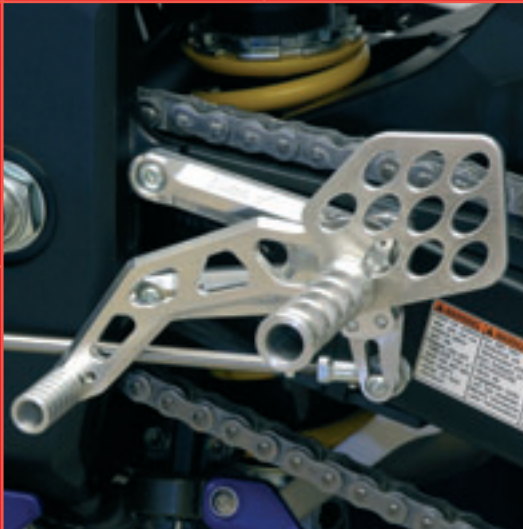

Die EVOLUTION kann mit High-Tech-Racingrasten MCF 907 und klappbaren Mitnehmern MCF 922 nachgerüstet werden. (Seite 1.10,1.11)

The rearsets can be fitted with High Tech racing footrests MCF 907 and foldable toe peg MCF 922. (Page: 1.10,1.11)

Ce produit peut être également adapté à des commandes reculées „Racing High Tech“ MCF 907 et „Flights“ repliables MCF 922. (Page: 1.10,1.11)



- fertig konfektionierte, CNC-gefräste Anlagen inklusive aller benötigten Befestigungsteile
- alle Anlagen sind zurück und nach oben zu verlegen
- Schalt- und Bremshebel laufen über Bronzebuchsen mit Graphitschmierung
- Schaltstangen aus Edelstahl
- Schalt- und Bremshebel mehrfach verstellbar
- Schaltung ist leichtgängig, wartungsfrei und witterungsbeständig
- Mitnehmer nach Fußlänge einstellbar

- ready-to-use assembly including all required fastening components
- highly stable CNC-manufactured aluminium products
- gear shift and brake pedal run in bronze bushings with graphite lubrication
- easy-action, maintenance-free, weatherproof gear shift
- levers with multiple adjustment facility
- levers can be adjusted for foot size
- stainless steel gear change rod

- produits en aluminium de très haute précision réalisés en commande numérique
- ces commandes sont relevées et reculées
- la pédale de freins et le sélecteur sont montés avec une bague en bronze et de la graisse graphitée
- la plupart des commandes permettent au sélecteur d'être réglable
- la tige de commande du sélecteur est réalisée en inox
- la pédale de freins et le sélecteur offrent de multiples possibilités de réglage
- les pilotes peuvent l'ajuster en fonction de leur pointure



Fußrastenanlagen mit TÜV
Rear sets
Kits de commandes reculées

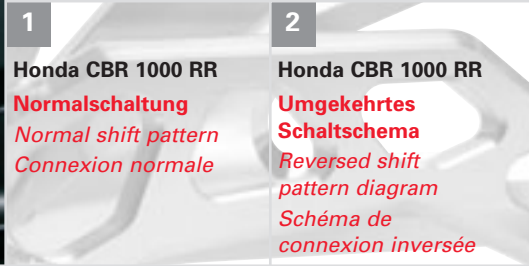
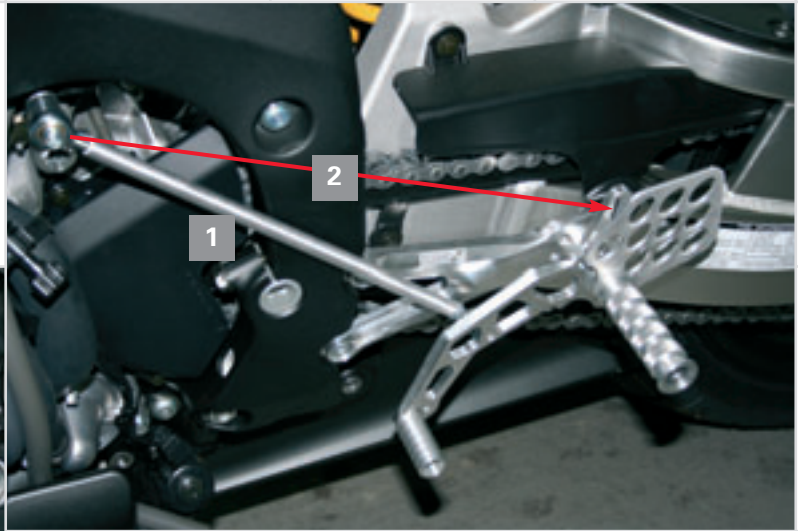

1
Honda CBR 1000 RR
Normalschaltung
Normal shift pattern
Connexion normale

2
Honda CBR 1000 RR
Umgekehrtes Schaltschema
Reversed shift pattern diagram
Schéma de connexion inversée

Mit TÜV-Gutachten, kein Eintrag in Schein oder Brief nötig!

Suzuki GSXR 1000
Montage vordere Lochreihe
Assembly pattern for front series of holes
Montage des lignes de trous avant



Suzuki GSXR 1000
Montage hintere Lochreihe
Assembly pattern for rear series of holes
Montage des lignes de trous arrière



- Leichter, kompakter Fußbremszylinder**
- CNC-gefräst, aus hochfestem Aluminium
 - variable Befestigungspunkte von 37–50 mm
 - passend für alle TRW Fußrastenanlagen
 - auch für Fremdfabrikate geeignet
 - Betätigung über Kugelgelenk M8
 - Kolbendurchmesser 12,8 mm

Fußbremszylinder mit TÜV-Gutachten!



MCF 911

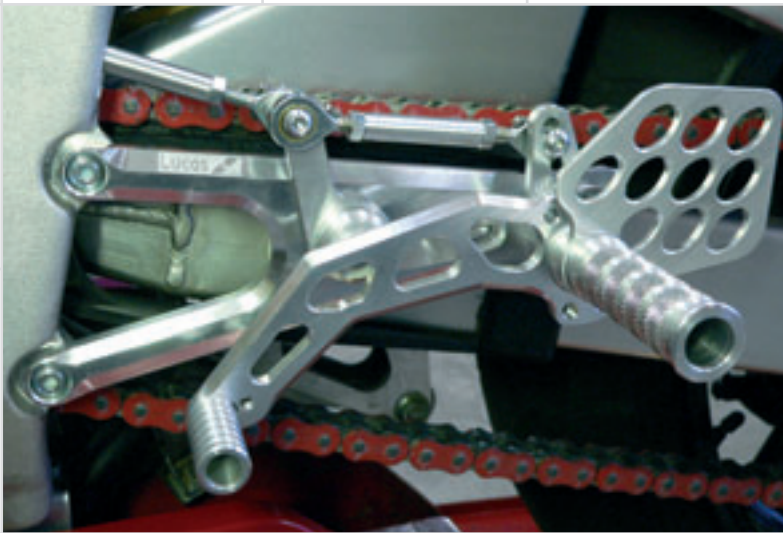

Bei fast allen Anlagen lässt sich ohne großen Aufwand die Schaltung umdrehen. Der Adapter an der Unterseite des Schalthebels wird dann mit der Schaltstange an der Oberseite des Schalthebels verschraubt.

With almost all units the gearshift pattern can be reversed without any great effort. The short gearshift rod is attached to the lower link of the pivot arm and the top of the gearshift lever.

Sur la plupart des kits de commandes reculées, la sélection peut s'inverser. Pour la sélection inversée, l'adaptateur entre le levier de sélection et les rotules se vissent sur la partie supérieure du sélecteur.

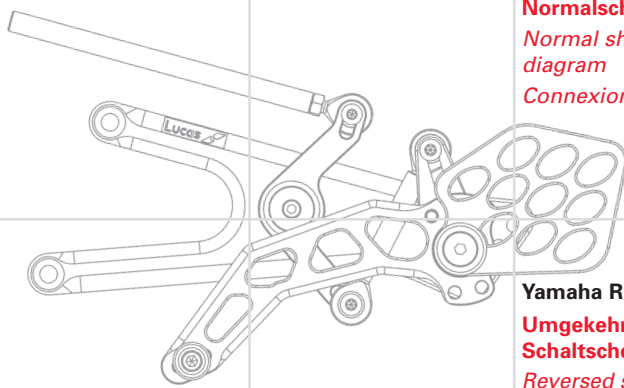

Yamaha R1
Normalschaltung
Normal shift pattern diagram
Connexion normale

Yamaha R1
Umgekehrtes Schaltschema
Reversed shift pattern diagram
Schéma de connexion inversée

Schaltstangenverlängerung bitte mitbestellen.

Gear change extensions must be ordered separately if required.

Les extensions de tiges de sélecteurs doivent aussi être commandées.

Lighter, more compact foot brake cylinder

- CNC-milled, in high-strength aluminium
- variable fixing points from 37-50 mm
- suitable for all TRW foot rest units
- also suitable for machines from other manufacturers
- activation by M8 ball joint
- piston diameter 12.8 mm

Cylindre de frein à pied plus léger et plus compact

- fraisé CNC, en aluminium supérieur
- points de serrage variables de 37-50 mm
- convient à tous les équipements d'étriers TRW
- indiqué également pour les produits étrangers
- fonctionnement avec une rotule M8
- diamètre de piston 12,8 mm

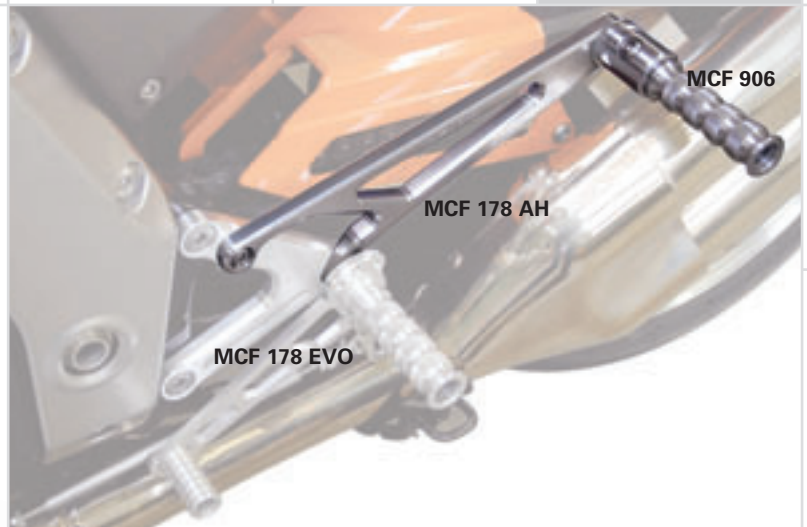











■ Die Anlage MCF 178 EVO, der Auspuffhalter MCF 178 AH und die Soziusrasten MCF 906 müssen getrennt bestellt werden.

■ The rear set MCF 178 EVO, the exhaust holder MCF 178 AH and the passenger footrests MCF 906 must all be ordered separately.

■ Le kit de commande reculée MCF 178 EVO, du pot d'échappement MCF 178 AH, et les repose-pieds passagés MCF 906 peuvent être commandés séparément.

Zubehör
Accessories
Accessoires

- M6   MCF 930
- M6   MCF 931
- M8   MCF 932
- M6   MCF 933
- M6   MCF 934



Hydraulischer Stopplightschalter
Hydraulic stoplight switch
Contacteur hydraulique pour le stop

Kugelgelenkköpfe
Ball joint
Rotules

Classic



MCF 502

MCF 462

Beide Hebel sind mehrfach verstellbar.
Both are with multiple adjustment.
Facilité de montage.



MCF 905

Bremshebel
Brake lever
Pédale de freins

Schalthebel
Gear shift lever
Sélecteur

Fußrasten-Teflonstopfen
Teflon footrest stopper set
Embouts de repose-pieds en Téflon blanc

2 Stück
2 pieces
2 pièces



MCF 907



MCF 903

MCF 902R

MCF 901 G

MCF 902P

MCF 903 B

Einzelne Ersatzrasten können zum Austausch in diversen Varianten und Farben nachbestellt werden.

Single rider rests can be ordered separately in a range of different colours.

Les différents repose-pieds peuvent être commandés en 3 modèles et en 5 couleurs.

High-Tech-Racingraste
High-tech racing rest
Commande racing high-tech

1 Stück
1 piece
1 pièce

Ersatzraste
Replacement rest
Commande de rechange

1 Stück
1 piece
1 pièce

Varianten
Models
Modèles

- Racing** MCF 901 x
- Standard** MCF 902 x
- Sport** MCF 903 x
- High-Tech** MCF 907

Farben
Colours
Couleurs

-  MCF ...
-  MCF ... R
-  MCF ... G
-  MCF ... P
-  MCF ... B

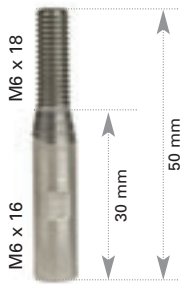

MCF 430

Schaltstangenverlängerung aus Edelstahl
Extension bracket for shifting rods
Tige d'extension sélecteur

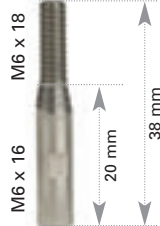

MCF 420

Evolution



MCF 562

Beide Hebel sind mehrfach verstellbar.
Both are with multiple adjustment.
Facilité de montage.

Schalthebel
Gear shift lever
Sélecteur

Evolution



MCF 504

Evolution



1 Stück
1 piece
1 pièce

MCF 922

Bremshebel
Brake lever
Pédale de freins

Classic



MCF 926

Evolution



MCF 526

Mitnehmer High-Tech klappbar, nur für Evolution-Hebel geeignet
High-tech folding toe peg, only fits Evolution rear set
Embouts en aluminium high-tech pliable, seulement adaptable sur les Evolution

Classic



MCF 920

Evolution



MCF 921

Fersenschutz Aluminium
Aluminium ankle guard
Protège-chevilles en aluminium

Mitnehmer
Toe peg
Embouts en aluminium

1 Stück
1 piece
1 pièce



MCF 431

Ersatz-Schaltstangen (Bitte das dazugehörige Modell angeben!)
Replacement shifting rods (Please state the exact type of motorcycle!)
Tiges de commandes sélecteur (Merci de préciser le type exact de la moto!)

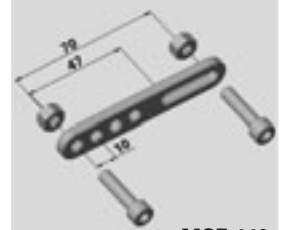

MCF 440

Adapter zur Verlegung von Bremsflüssigkeitsbehältern
Adapter for relocating brake fluid reservoirs
Adaptateur pour la pose du réservoir à liquide de frein



MCZ 530



MCZ 531



MCZ 530 S
 MCZ 530 C



MCZ 531 S
 MCZ 531 C

Minibehälter, Kunststoff, 15 ml
Mini style reservoir, plastic
Réservoir de liquide, plastique

Minibehälter, Aluminium, 15 ml
Mini style fluid reservoir, aluminium
Réservoir de liquide, aluminium

S = schwarz, C = chrom
S = black, C = chrome
S = noire, C = chromée



Design



mm



mm

**Aprilia**

RSV	1000	Mille	ME	98-00	MCF 106 RAC	Racing	5-35	5-20	5)
RSV	1000	Mille	RP	01-03	MCF 106 RAC	Racing	5-35	5-20	5)
RSV	1000	Mille R	RP	01-03	MCF 106 RAC	Racing	5-35	5-20	5)
RSV	1000	Mille SP	RP	01-03	MCF 106 RAC	Racing	5-35	5-20	5)
RSV	1000	Mille	RR	04-	MCF 107 RAC	Racing	5-35	5-20	

BMW

R	850	R	259	95-	MCF 100 B		40	30	
R	1100	RS	247	93-	MCF 100 B		40	30	
R	1100	R	259	95-	MCF 100 B		40	30	
R	1100	S	R2S	98-	MCF 101 B		30	10	

Ducati

600	Monster	M3	00-	MCF 112 Evo	Evolution	35	35	1) 2) 5)
600	Monster	M	93-99	MCF 112 Evo	Evolution	35	35	1) 2) 5)
748	, SPS	748	94-	MCF 111 D		35	10	
750	SS	S	93-	MCF 110 Evo	Evolution	30	30	
750	Monster	M	96-	MCF 112 Evo	Evolution	35	35	1) 2) 5)
851	UPS		92-	MCF 112 Evo	Evolution	35	35	5)
888	SPS	ZDM888S	93-	MCF 112 Evo	Evolution	35	35	5)
900	Monster	M	93-	MCF 112 Evo	Evolution	35	35	1) 2) 5)
900	SL	S	93-	MCF 110 Evo	Evolution	30	30	
900	SS	S	93-	MCF 110 Evo	Evolution	30	30	
916	, SPS		94-	MCF 110 Evo	Evolution	30	30	
996		H	97-	MCF 110 Evo	Evolution	30	30	
998	R, S	H2	02-	MCF 110 Evo	Evolution	30	30	
1000	Monster		03-	MCF 112 Evo	Evolution	35	35	5)

Honda

CB	600	Hornet	PC36	01-	MCF 190 Evo	Evolution	30	30	1) 5)
CB	600	Hornet	PC34A	98-00	MCF 190 Evo	Evolution	30	30	1) 5)
CBR	600	RR	PC37/PC40	03-	MCF 194 Evo	Evolution	35	25	3) 5)
CBR	600	RR	PC37/PC40	03-	MCF 195 RAC	Racing	5-35	5-20	
CBR	600	F	PC35	99-	MCF 128 Evo	Evolution	30	30	5)
CB	900	Hornet	SC48	02-	MCF 190 Evo	Evolution	30	30	1) 5)
CBR	900	RR	SC44	00-01	MCF 191 Evo	Evolution	25	15	5)
CBR	950	RR	SC50	02-03	MCF 191 Evo	Evolution	25	15	5)
CBR	1000	RR	SC57	04-	MCF 195 Evo	Evolution	31	27	3) 5)
CBR	1000	RR	SC57	04-	MCF 195 RAC	Racing	5-35	5-20	

Kawasaki

ZXR	400	L	ZX400L	91-	MCF 133 K		30	30	
ZX-6R	600	Ninja	ZX600H	98-00	MCF 138 K		40	15	
ZX-6R	600	Ninja	ZX600J	01	MCF 138 K		40	15	
ZX-6R	600	RR	ZX600K	03-04	MCF 177 K		30	20	
ZX-6R	600	RR	ZX600N	05-06	MCF 114 Evo	Evolution	30	20	5)
ZX-6R	600	Ninja	ZX600P	07-	MCF 198 RAC	Racing	5-35	5-20	
ZZR	600	E	ZX600E	93-	MCF 134 K		25	25	
ZX-6R	636	Ninja	ZX636A	02	MCF 138 K		40	15	
ZX-6R	636	Ninja	ZX636B	03-04	MCF 177 K	Classic	30	20	
ZX-6R	636	Ninja	ZX636C	05-06	MCF 114 Evo	Evolution	30	20	5)
Z	750		ZR750J	04-	MCF 178 Evo	Evolution	35	30	5)
ZR-7	750		ZR750F	99-	MCF 172 K		45	25	
ZX-7R	750	Ninja	ZX750N	96-02	MCF 132 K		30	30	8)
ZX-7R	750	Ninja	ZX750P	96-02	MCF 132 K		30	30	9)
ZX-9R	900	Ninja	ZX900E	00-03	MCF 139 Evo	Evolution	40	15	
ZX-9R	900	Ninja	ZX900C/D	98-99	MCF 139 Evo	Evolution	40	15	
Z	1000		ZRT00A	03-06	MCF 178 Evo	Evolution	35	30	10) 5)
ZX-10R	1000	Ninja	ZX100C	04-05	MCF 179 Evo	Evolution	25	20	
ZX-10R	1000	Ninja	ZXT00C	06-	MCF 171 Evo	Evolution			5)
ZRX	1100		ZRT10C	97-	MCF 137 K		30	30	
ZX-12	1200		ZXT20A	00-	MCF 175 Evo	Evolution	25	20	5)



Design



mm



mm

**Suzuki**

GSF	600	Bandit	GN77B	94-99	MCF 145 Evo	Evolution	30	50	5)
GSF	600	Bandit	WVA8	00-04	MCF 145 Evo	Evolution	30	50	5)
GSXR	600		AD311	96-00	MCF 183 Evo	Evolution	30	30	5)
GSXR	600		AD311	01-03	MCF 183 Evo	Evolution	20	25	5)
GSXR	600		WVB2	04-05	MCF 183 Evo	Evolution	34	24	5)
GSXR	600		CE	06-	MCF 187 Evo	Evolution			5)
GSXR	600		CE	06-	MCF 187 RAC	Racing	5-35	5-20	
RF	600	R, RU	GN76B	93-96	MCF 148 S		30	30	
SV	650		WVBY	03-	MCF 183 Evo	Evolution	34	24	5)
SV	650		AV111	98-02	MCF 183 Evo	Evolution	30	30	5)
GSXR	750		GR77B	88-89	MCF 142 Evo	Evolution	20	20	
GSXR	750		GR7AB	90-91	MCF 142 Evo	Evolution	20	20	
GSXR	750		GR7DB	96-99	MCF 183 Evo	Evolution	30	30	5)
GSXR	750		WVBD	00-03	MCF 183 Evo	Evolution	20	25	5)
GSXR	750		WVB3	04-05	MCF 183 Evo	Evolution	34	24	5)
GSXR	750		CF	06-	MCF 187 Evo	Evolution			5)
GSXR	750		CF	06-	MCF 187 RAC	Racing	5-35	5-20	
RF	900	R	GT73B	94-96	MCF 149 S		30	30	
GSXR	1000		WVBL	01-02	MCF 183 Evo	Evolution	20	25	5)
GSXR	1000		WVBZ	03-04	MCF 183 Evo	Evolution	34	24	5)
GSXR	1000		WVB6	05-06	MCF 186 Evo	Evolution	35	25	5)
GSXR	1000		WVCL	07-	MCF 196 RAC	Racing	5-35	5-20	
SV	1000		WVBX	03-	MCF 183 Evo	Evolution	34	24	5)
TL	1000	S	AG111	97-	MCF 146 S		30	30	
GSXR	1100		GV73C	89-92	MCF 142 Evo	Evolution	20	20	
GSF	1200	Bandit	GU75C	96-00	MCF 145 Evo	Evolution	30	50	5)
GSF	1200	Bandit	WVA9	01-	MCF 145 Evo	Evolution	30	50	5)

Triumph

TT	600			99-	MCF 161 T		23	15	
	675	Daytona	MD	07-	MCF 197 RAC	Racing	5-35	5-20	

Yamaha

YZF	600	R6	RJ03	99-02	MCF 158 Y		35	10	3)
YZF	600	R6	RJ11	06-	MCF 169 Evo	Evolution			5)
FZR	1000		3LE	90-95	MCF 153 Y		25	25	
FZS	1000	Fazer	RN06	01-	MCF 165 Y	Classic	25		
YZF	1000	R1	RN01	98-00	MCF 157 Evo	Evolution	40	15	3) 5)
YZF	1000	R1	RN04	01	MCF 157 Evo	Evolution	40	15	3) 5)
YZF	1000	R1	RN09	02-03	MCF 166 Evo	Evolution	20		3) 5)
YZF	1000	R1	RN12	04-06	MCF 168 Evo	Evolution	20		3) 5)
YZF	1000	R1	RN19	07-	MCF 199 RAC	Racing	5-35	5-20	
VMX	1200	V-Max		86-	MCF 156 Y				6)

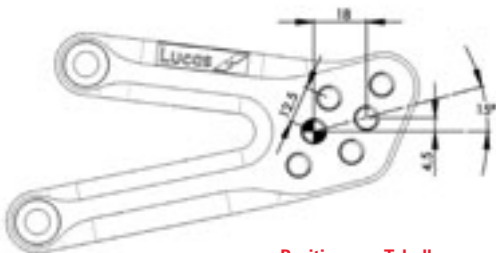
EVOLUTION

Position aus Tabelle
Position from table
Position du tableau

Abverkauf

- 1) Soziasanlage entfällt
- 2) ohne Auspuffhalter
- 3) inkl. Umkehrschaltung
- 4) Kürzung des Seitenständers nötig
- 5) 6-fache Verstellmöglichkeit (siehe Skizze)
- 6) geänderte Bremsleitung MCH 401 H1 nötig, inkl. Soziasrasten
- 7) Schaltung außerhalb des Rahmens
- 8) geänderte Bremsleitung MCH 102 H1 nötig
- 9) geänderte Bremsleitung MCH 125 H1 nötig
- 10) MCF 178 AH + (Auspuffhalter) MCF906 (Soziasrasten) separat bestellen

running out

- 1) pillion omitted
- 2) without exhaust support
- 3) including inverted gearchange
- 4) Shortening of the side stand required
- 5) 6 way adjustability (view outline)
- 6) modified rear brake hose MCH 401 H1 required, incl. pillion rider footrest
- 7) gearchange outside the frame
- 8) modified rear brake hose MCH 102 H1 required
- 9) modified rear brake hose MCH 125 H1 required
- 10) MCF 178 AH (exhaust bracket) MCF906 (pillion rider footrests) separate

vente à part

- 1) pieds passager supprimer
- 2) sans le support d'échappement
- 3) sélecteur inversé inclus
- 4) Raccourcissement du support latéral nécessaire
- 5) 6 positions de réglages (voir schéma)
- 6) durite arrière à modifier MCH 401 H1 nécessaire, inclus. cran associé
- 7) tiges de commande sélecteur hors du cadre
- 8) durite arrière à modifier MCH 102 H1 nécessaire
- 9) durite arrière à modifier MCH 125 H1 nécessaire
- 10) MCF 178 AH (support du tuyau d'échappement) MCF906 (crans associés) séparé

Austausch-Fußrasten mit ABE

Replacement footrests

Repose-pieds

- Gelenk und Rastenröhrchen bitte getrennt bestellen, beides wird als Satz geliefert
- extravagantes und überzeugendes Design
- passend für die Originalhalterung
- Beibehaltung des Klappmechanismus
- auf Lucas-Rastenanlagen abgestimmtes Design
- harmonische Länge der Rasten ermöglicht sportliches Fahrverhalten bei größerer Bodenfreiheit
- die Rasten können mit MCF 905 geschlossen werden

- to obtain a complete set, joints and footrests bars must be ordered separately, both parts are delivered in pairs
- extravagant and imposing design
- suitable for the original mountings
- the folding mechanism is retained
- design fits all Lucas footrests
- the rests are designed to give increased ground clearance
- designed to fit MCF 905 teflon stoppers

- pour avoir un set complet, les supports et les tubes de repose-pieds sont à commander séparément; chaque référence est livrée par paire
- adaptable sur les supports d'origines
- avec le système de blocage
- dans le même design que la gamme Lucas commandes reculées
- le style des repose-pieds facilite la conduite jusque dans un style racing
- le bout des repose-pieds peut être bouché par les embouts en téflon MCF 905

Alle Artikel werden als Satz geliefert.

All articles are supplied as pairs.

Tous les articles seront livrés en kit.



MCF 905

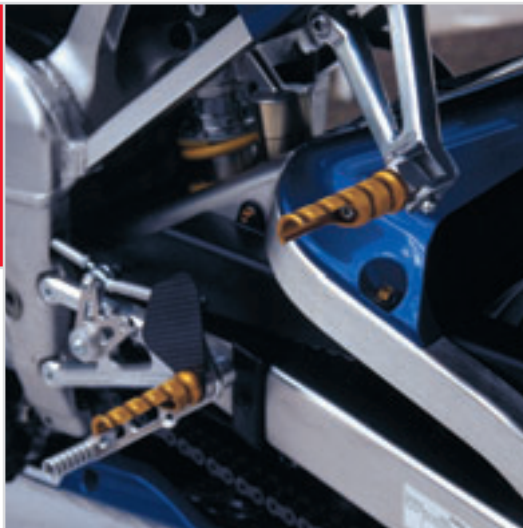

Fußrasten-Teflonstopfen

Teflon footrest stopper set

Embouts de repose-pieds en Téflon blanc

2 Stück
2 pieces
2 pièces

Standard Racing



MCF 900



MCF 904

Bitte geben Sie hinter der Artikelnummer des Rastenröhrchens die gewünschte Farbe an.

Please enter the colour you require after the part number of the footrest.

Veillez préciser la couleur désirée dans la référence du repose-pieds.

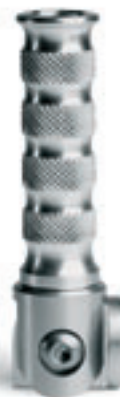

MCF 906

Inkl. Gelenk mit M8-Schraube von hinten zu befestigen (ohne ABE).

Including joint with M8 screw to fasten from the rear.

Incluant un joint et une vis M8 pour un serrage de la partie arrière.

Farben
Colours
Couleurs

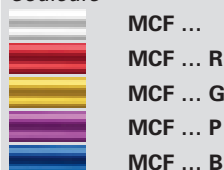

Universalrasten in silber
Universal rests in silver
Commande reculée universelle argent

2 Stück
2 pieces
2 pièces



BMW

R	850	R	259	95-	MCF 300	MCF 200
R	1100	R/RS/RT	259	95-	MCF 300	MCF 200
R	1100	S	R2S/R11S	98-	MCF 301	MCF 201

Ducati

600	SS	ZDM600S	91-97	MCF 310	MCF 210	
600	Monster	ZDM600M/M3	94-01	MCF 311	MCF 311	
620	Monster	ZDMM4	02-	MCF 311	MCF 311	
748	, R	ZDMH3/748S	95-03	MCF 312	MCF 311	
750	Monster	ZDMM1	96-	MCF 311	MCF 311	
750	SS	ZDM750SC	91-98	MCF 310	MCF 210	
750	SS i.e.	ZDMV2	99-	MCF 310	MCF 210	
800	Monster i. E.	M4	03-	MCF 311	MCF 311	
851	UPS		92-	MCF 310	MCF 210	
888			93-	MCF 310	MCF 210	
900	SS	ZDM906SC2	91-98	MCF 310	MCF 210	
900	SS i.e.	ZDMV1	98-01	MCF 310	MCF 210	
900	Monster		93-98	MCF 311	MCF 311	
900	Monster i. E.	ZDMM2	99-	MCF 311	MCF 311	
S4	900	Monster	ZDMM4	01-	MCF 311	MCF 311
900	SL		91-	MCF 310	MCF 210	
907	i. E.		91-92	MCF 310	MCF 210	
916		ZDM916S	94-98	MCF 312	MCF 311	
944	ST2/ST4	ZDMS1/S2	97-	MCF 310	MCF 210	
996	, SPS, R	ZDMH2	98-	MCF 312	MCF 311	
998	, S, R	ZDMH2	98-	MCF 312	MCF 311	
998	ST 4 S	ZDMH2	02-	MCF 310	MCF 210	
1000	Monster i. E.	M4	03-	MCF 311	MCF 311	

Honda

CB	600	F Hornet	PC 34	98-00	MCF 320	MCF 223
CB	600	F Hornet	PC 36	01-	MCF 320	MCF 224
CBR	600	F	PC 23/25	89-94	MCF 320	MCF 223
CBR	600	F	PC 31/35	95-	MCF 320	MCF 220
CBR	600	RR	PC 37	03-	MCF 320	MCF 220
VFR	800		RC46	98-	MCF 320	MCF 220
CBR	900	RR	SC28/33/44/50	92-03	MCF 320	MCF 220
CB	900	Hornet	SC 48	02-	MCF 320	MCF 225
CB	1000	Big One	SC 30	93-96	MCF 320	MCF 220
CBR	1000	F	SC 24	89-93	MCF 320	MCF 223
CBR	1000	RR Fireblade	SC 57	04-	MCF 320	MCF 220
VTR	1000	Firestorm	SC 36	97-	MCF 320	MCF 220
VTR	1000	SP1/ SP2	SC 45	00-	MCF 320	MCF 220
XL	1000	Varadero	SD 01	99-	MCF 320	MCF 220
CBR	1100	XX	SC 35	97-	MCF 320	MCF 220
1100	X-Eleven	SC 42	99-	MCF 320	MCF 220	

Kawasaki

ZXR	400	L	ZX 400L	91-	MCF 330	MCF 230
ZR	550	Zephyr	ZR 550B	90-99	MCF 330	MCF 230
GPX	600	R	ZX 600A/B	87-	MCF 330	MCF 230
GPZ	600	R	ZX 600 A	85-88	MCF 330	MCF 230
ZZR	600		ZX 600 D/E	89-	MCF 330	MCF 230
ZX-6R	600	Ninja	ZX 600 F/G	93-99	MCF 330	MCF 230
ZX-6R	600	Ninja	ZX 600 J	00-	MCF 330	MCF 231
ZX-6R	636	Ninja	ZX 636 A/B	02-04	MCF 330	MCF 231
ZX-6R	636	Ninja	ZX 636 C	05-	MCF 331	MCF 231
ER-6	650	N, F	ER 650A	05-	MCF 331	MCF 231
GPZ	750	Turbo	KZ 750 E	84-88	MCF 330	MCF 230
Z	750		ZR 750J	04-	MCF 330	MCF 230
ZR	750	Zephyr	ZR 750 C/D	91-	MCF 330	MCF 230
ZR 7	750		ZR 750 F	99-	MCF 330	MCF 230
ZX-7R	750	Ninja	ZX 750 P/N	95-	MCF 330	MCF 230
ZXR	750	, R	ZX 750 H/J/K/L	89-95	MCF 330	MCF 230
GPZ	900	R	ZX 900 A	84-97	MCF 330	MCF 230
ZX-9R	900	Ninja	ZX 900 B/C	93-99	MCF 330	MCF 230
ZX-9R	900	Ninja	ZX 900 E	00-03	MCF 330	MCF 231
Z	1000		ZRT00A	03-	MCF 330	MCF 231
ZX-10	1000		ZXT00B	88-92	MCF 330	MCF 230
ZX-10	1000	Ninja	ZXT00C	04-05	MCF 330	MCF 231
ZX-10	1000	Ninja	ZXT00D	06-	MCF 331	MCF 231
GPZ	1000	RX	ZXT00A	86-90	MCF 330	MCF 230
GPZ	1100		ZXT10E	94-96	MCF 330	MCF 230



Kawasaki

ZR	1100	Zephyr	ZRT10A	92-	MCF 330	MCF 230
ZRX	1100		ZRT10C	97-00	MCF 330	MCF 230
ZZR	1100		ZXT10C/D	90-01	MCF 330	MCF 230
ZRX	1200		ZRT20A	01-	MCF 330	MCF 231
ZX-12	1200		ZXT20 A	00-	MCF 330	MCF 231
ZZR	1200		ZXT20C	02-	MCF 330	MCF 231

Suzuki

GSF	600	Bandit	GN77B	94-99	MCF 340	MCF 243
GSF	600	Bandit	WVA8	00-04	MCF 340	MCF 243
GSR	600		WVB9	06-	MCF 344	MCF 247
GSXR	600		AD	96-00	MCF 341	MCF 243
GSXR	600		WVBG	01-03	MCF 342	MCF 243
GSXR	600		WVB2	04-05	MCF 342	MCF 245
GSXR	600		WVCE	06-	MCF 344	MCF 247
RF	600	R, RU	GN76B	93-97	MCF 340	MCF 341
GSF	650	Bandit	WVB5	05-	MCF 344	MCF 245
SV	650	, S	AV	99-02	MCF 341	MCF 243
SV	650	, S	WVBY	03-	MCF 342	MCF 245
GSX	750		AE	99-	MCF 340	MCF 243
GSXR	750		GR77B/GR7AB/BB	88-95	MCF 341	MCF 341
GSXR	750		GR7DB	96-99	MCF 341	MCF 243
GSXR	750		WVBD	00-03	MCF 342	MCF 243
GSXR	750		WVB3	04-05	MCF 342	MCF 245
GSXR	750		WVCF	06-	MCF 344	MCF 247
RF	900	R	GT73B	94-97	MCF 340	MCF 340
GSXR	1000		WVBL	01-03	MCF 342	MCF 243
GSXR	1000		WVBZ	04	MCF 342	MCF 245
GSXR	1000		WVB6/WVCL	05-	MCF 344	MCF 247
SV	1000	, S	WVBX	03-	MCF 342	MCF 245
TL	1000	S, R	AG/AM	97-	MCF 341	MCF 243
GSXR	1100		GV73C/GU75C	88-97	MCF 340	MCF 340
GSF	1200	Bandit	GV75A	96-99	MCF 340	MCF 340
GSF	1200	Bandit	WVA9/WVCB	00-06	MCF 340	MCF 340
GSX	1200		A3	99-	MCF 341	MCF 243
GSXR	1300	Hayabusa	WVA1	99-	MCF 320	MCF 243
GSX	1400		WVBN	02-	MCF 341	

Triumph

750/900	Trident	T300C	94-	MCF 360	MCF 260
900/1200	Dayt.	T300D	94-96	MCF 360	MCF 260
900/1200	Trophy	T300E	94-96	MCF 360	MCF 260
900	Sprint	T300A	93-97	MCF 360	MCF 260
900	Thunderbird	T309RT	95-98	MCF 360	MCF 260
900	Speed Triple	T300B	94-96	MCF 360	MCF 260

Yamaha

SR	500		2J4 /48T	78-98	MCF 351	MCF 251
FSZ	600	Fazer	RJ02	98-	MCF 350	MCF 250
FZ6	600	, Fazer	RJ07	04-	MCF 350	MCF 250
FZR	600	alle Modelle	3HE/3RG/3RH/4FH..	89-95	MCF 350	MCF 250
SRX	600		1XL/1XM	86-90	MCF 350	MCF 250
XJ	600		51J/3KM/3KN/4BR/4LX	84-	MCF 350	MCF 250
YZF	600	R	4TV/4WD	96-	MCF 350	MCF 250
YZF	600	R 6	RJ03	99-02	MCF 350	MCF 250
YZF	600	R 6	RJ05/RJ09/RJ11	03-	MCF 352	MCF 253
SZR	660		4SU	96-	MCF 350	MCF 250
FZ	750		1FN/2KK/3KT	85-96	MCF 350	MCF 250
YZF	750	R, SP	4HN/4HT	93-96	MCF 350	MCF 250
TDM	850		4CM/3VD/4TX	91-99	MCF 350	MCF 250
TRX	850		4UN	96-	MCF 350	MCF 250
XJ	900		58L/4BB/4KM	85-97	MCF 350	MCF 250
FZR	1000		2LA/3LE	87-95	MCF 350	MCF 250
FZS	1000	Fazer	RN06	02-	MCF 350	MCF 252
FZ 1	1000	, Fazer	RN16	06-	MCF 350	MCF 252
YZF	1000	R	4VD	96-	MCF 350	MCF 250
YZF	1000	R1	RN01	98-99	MCF 350	MCF 250
YZF	1000	R1	RN04/RN09/RN12/RN19	00-	MCF 352	MCF 253
BT	1100	Bulldog	RP05	02-	MCF 350	MCF 250
XJR	1200		4PU	94-	MCF 350	MCF 250
FJR	1300		RP04	02-	MCF 350	MCF 250
XJR	1300		RP02/RP06/RP10	99-	MCF 350	MCF 250