

**Lenker**  
*Handlebars*  
*Guidons*

**Aluminiumlenker mit ABE**

*Aluminium handlebars*

*Guidons aluminium*

Superbike 22 mm

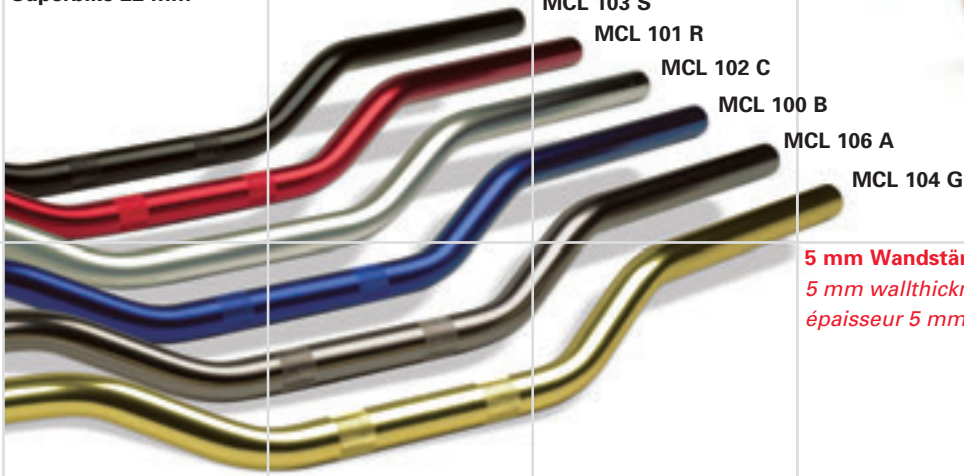

**5 mm Wandstärke**  
*5 mm wallthickness*  
*épaisseur 5 mm*

Superbike 28 mm



MCL 152 C

**Jetzt neu mit ABE. Kein TÜV mehr nötig!**

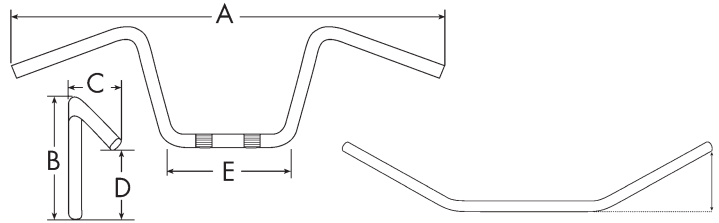

**Konisch**  
*Conical*  
*Conique*

**Standard**



**2 Stück**  
*2 pieces*  
*2 pièces*

**Lenkerenden für Lenker mit 5 mm Wandstärke**

*Bar ends for 5 mm wallthickness*  
*Embouts pour guidons 5 mm d'épaisseur*





















**Classic**



Speedfighter 22 mm



**5 mm Wandstärke**  
*5 mm wallthickness*  
*Épaisseur 5 mm*

<b>MCL 100 B</b>		Superbike	<b>MCL 200 B</b>	<b>MCL 212-B</b>	750	53	230	110	178	110	22
<b>MCL 101 R</b>		Superbike	<b>MCL 201 R</b>	<b>MCL 212-R</b>	750	53	230	110	178	110	22
<b>MCL 102 C</b>		Superbike	<b>MCL 202 C</b>	<b>MCL 212-C</b>	750	53	230	110	178	110	22
<b>MCL 103 S</b>		Superbike	<b>MCL 203 S</b>	<b>MCL 212-S</b>	750	53	230	110	178	110	22
<b>MCL 104 G</b>		Superbike	<b>MCL 204 G</b>	<b>MCL 212-G</b>	750	53	230	110	178	110	22
<b>MCL 106 A</b>		Superbike	<b>MCL 203 S</b>	<b>MCL 212-T</b>	750	53	230	110	178	110	22
<b>MCL 150 B</b>		Speedfighter			850	60	220	80	200	50	22
<b>MCL 150 C</b>		Speedfighter			850	60	220	80	200	50	22
<b>MCL 150 T</b>		Speedfighter			850	60	220	80	200	50	22
<b>MCL 152 C</b>		Superbike		<b>MCL 214-C</b>	770	70	190	100	180	100	28
<b>MCL 153 B</b>		MC Low			800	65	190	85	180	85	22
<b>MCL 153 C</b>		MC Low			800	65	190	85	180	85	22
<b>MCL 153 T</b>		MC Low			800	65	190	85	180	85	22
<b>MCL 154 B</b>		MC Medium			800	80	190	100	180	90	22
<b>MCL 154 C</b>		MC Medium			800	80	190	100	180	90	22
<b>MCL 154 T</b>		MC Medium			800	80	190	100	180	90	22
<b>MCL 155 B</b>		Off-road High			800	110	190	120	180	110	22
<b>MCL 155 C</b>		Off-road High			800	110	190	120	180	110	22
<b>MCL 155 T</b>		Off-road High			800	110	190	120	180	110	22
<b>MCL 156 C</b>		Enduro		<b>MCL 214-C</b>	800	110	190	120	180	85	28
<b>MCL 157 C</b>		MC, SuperMoto		<b>MCL 214-C</b>	810	70	190	110	180	65	28

**Farben**    **B** blau    **C** silber    **G** gold    **R** rot    **S** schwarz    **T/A** titan  
*Colours*    blue    silver    gold    red    black    titanium  
*Couleurs*    bleu    argent    or    rouge    noir    titane

**Off-Road 28 mm**



**MCL 156 C**  
**MCL 157 C**



**MCL 650**

**Satz Klemmböckchen für 28-mm-Lenker**  
*Set of small clamp plates for 28 mm handlebar*  
*Pontets pour guidon 28 mm*



**2 Stück**  
*2 pièces*  
*2 pièces*

**Konisch, perlsandgestrahlt**  
*Conical, sandblasted*  
*Conique, couleur sable*

**Off-Road 22 mm**



**MCL 155 C**

**MCL 154 T**

**MCL 153 B**

**Jetzt neu mit ABE. Kein TÜV mehr nötig!**

**Lenker mit Mittelstrebe in 4 mm Wandstärke**  
*Handlebars with brace, 4 mm wallthickness*  
*Guidon avec barre de renforcement épaisseur 4 mm*



	0365	0366	0367	0368	0369	0370	0371	0372
MCL	100-106	150	153	154	155	152	156	157

### Aprilia

MX 125	TZ	04-						
SXV 450/550		06-						
RXV 450/550		06-						
Pegaso 650	GA	93-94						
Pegaso 650	MX	95-						
Pegaso 650	ML	96-						
RSV 1000 Tuono	RP	03-						

### BMW

F 650	BMW 259	94-00						
F 650 GS	R13	01-						
F 650 Dakar	R13	01-						
R 850 R	BMW 259	93-00						
R 850 R	R21	01-						
R 1100 GS	BMW 259	93-99						
R 1100 R	BMW 259	93-00						
R 1150 GS	R21	99-						
R 1150 R	R21	01-						
R 1200 GS	R12	04-						

### Ducati

Monster 400	M3	98-01						
Monster 600	M	94-97						
Monster 600	M3	98-01						
Monster 620	M4	02-						
Monster 695	M4	07-						
Monster 750	M	97-01						
Monster 750	M4	01-						
Monster 800	M4	03-						
Monster 800 SR2	M4	05-						
Monster 900	M2	99-						
Monster 900	M4	00-						
Monster 900	M	94-99						
Monster 996 S4R	M4							
Monster 1000 i.e.	M4	03-						

### Honda

XL 125 Varadero	JC 32	01-						
XR 125	JD 19	03-						
CB 250 Two fifty	MC 26	92-						
CB 400 N	CM400N	78-82						
CB 500	PC 26	94-96						
CB 500	PC 32	97-03						
CBF 500	PC 39	04-						
CB 600 Hornet	PC 34	00-01						
CB 600 Hornet	PC 36	02-06						
CB 600 Hornet	PC 41	07-						
FMX 650	RD 12	05-						
NT 650 Deauville	RC 47	98-						
NTV 650	RC 33	88-97						
NX 650 Dominator	RD 08	88-						
SLR 650	RD 09	97-98						
XL 650 Transalp	RD 10	00-						
NT 700 Deauville	RC 52	06-						
CB 750 seven fifty	RC 42	92-03						
XRV 750 Africa Twin	RD 04	89-03						
XRV 750 Africa Twin	RD 07	93-						
CB 900 Hornet	SC 48	02-						
CB 1000 Big	SC 30	92-96						
GL 1000	GL1	75-81						
XL 1000 Varadero	SD 01	99-						
CB 1100 X-11	SC 42	00-						
CB 1300 X-4	SC 54	03-						

### Husaberg

FE 400	Husaberg FE	00-						
FE 400 E	Husaberg FE	01-						
FS 400 C	Husaberg FE	01-						
FS 400 E	Husaberg FE	01-						
FC 501 CR	YU7FC...	00-						
FE 501	Husaberg FE	00-						
FE 501 E	Husaberg FE	01-						
FC 600 CR	YU7FC...	00-						
FE 600	Husaberg FE	00-						
FE 600 Supermotard	Husaberg FE	00-						
FS 650 C	Husaberg FE	01-						
FS 650 E	Husaberg FE	01-						



	0365	0366	0367	0368	0369	0370	0371	0372
MCL	100-106	150	153	154	155	152	156	157

### Hyosung

125 Karion	RTT	04-	✗					
GT 125 naked	GT	03-	✗					
XRX 125	RX	01-			✗	✗	✗	
GT 250 naked	GT	03-	✗					
GT 650 naked	GT 650	03-	✗					

### Kawasaki

KLR 250	KL250D	84-90			✗	✗	✗	
ER-5, Twister	ER500A	96-	✗	✗				
ER-6F	EX650A	05-	✗	✗				
ER-6N	ER650A	05-	✗	✗				
KLE 500	LE500A	91-			✗	✗	✗	
ZR 550 Zephyr	ZR550B	91-99	✗	✗				
ZL 600 Eliminator	ZL600B	95-97	✗	✗				
KLR 650	KL650A	87-			✗	✗	✗	
KLX 650	LX650A	93-95			✗	✗	✗	
Versys 650	LE650A	06-					✗	
Z 750	ZR750J	04-	✗	✗				
Z 750 S	ZR750J	05-	✗	✗				
Z 750	ZR750L	07-	✗	✗				
ZR 750 Zephyr	ZR 750C	91-99	✗	✗				
ZR-7	ZR750F	99-	✗	✗				
ZR-7 S	ZR750F	01-	✗	✗				
KLV 1000	WVBS	04-	✗	✗				
Z 1000	ZRT00A	03-06	✗	✗				
Z 1000	ZRT00B	07-	✗	✗				
ZR 1100 Zephyr	ZRT 10A	91-	✗	✗				
ZRX 1100 R,S	ZRT10C	97-00	✗	✗				
ZRX 1200 R,S	ZRT20A	01-	✗	✗				

### KTM

400 EXC Racing		00-						✗	✗
400 SX Racing		00-						✗	✗
450 EXC Racing		03-						✗	✗
525 SX Racing		03-						✗	✗
525 MXC								✗	✗
625 SXC		03-						✗	✗
LC4 Adventure		00-						✗	✗
LC8 950 Adventure		02-						✗	✗
950 Duke		03-						✗	✗
990 Super Duke		04-						✗	✗

### MUZ

RT 125	RT 125	02-	✗		✗	✗	✗		
MZ 125 SX	MZ 125	01-			✗	✗	✗		
MZ 125 SM	MZ 125	03-			✗	✗	✗		

### Suzuki

DR 125	SF43B	91-	✗		✗	✗	✗		
DR 125	SF44A	95-	✗		✗	✗	✗		
DR 350	SK42B	90-97	✗		✗	✗	✗		
DR-Z 400 S	BE, BF	00-	✗		✗	✗	✗		
DR-Z 400 SM	WVBC	05-	✗		✗	✗	✗		
DR-Z 400 SM	WVB8	07-						✗	✗
GS 500	GM51B	89-	✗	✗					
GSF 600 Bandit	GN 77B	95-99	✗	✗					
GSF 600 Bandit	WVA8	00-04	✗	✗					
GSF 650 Bandit	WVB5	05-	✗	✗					
GSR 600	WVB9	06-	✗	✗					
DL 650 V-Strom	WVB1	04-	✗						
DR 650	SP42B	90-	✗		✗	✗	✗		
DR 650	SP43B	91-	✗		✗	✗	✗		
DR 650	SP44B	92-	✗		✗	✗	✗		
DR 650	SP45B	93-	✗		✗	✗	✗		
DR 650	SP46B	95-	✗		✗	✗	✗		
SV 650 N	AV	99-02	✗	✗					
SV 650 N	WVBY	03-	✗	✗					
XF 650 Freewind	AC	97-	✗			✗	✗		
GSX 750	AE	98-01	✗	✗					
DR 800	SR42B	96-	✗		✗	✗	✗		
DR 800	SR43B	92-	✗		✗	✗	✗		
DL 1000 V-Strom	WVBS	02-	✗				✗		
SV 1000 N	WVBX	03-	✗	✗					



	0365	0366	0367	0368	0369	0370	0371	0372
MCL	100-106	150	153	154	155	152	156	157

### Suzuki

GSX 1100 G	GV74A	91-96	X	X				
GSF 1200 N,S	GV 75A	96-00	X	X				
GSF 1200 N,S	WVA9	01-06	X	X				
GSF 1250 N,S	WVCH	07-	X	X				
GSX 1200	A3	99-01	X	X				
GSX 1400	WVBN	02-	X	X				

### Triumph

Speed Triple 900	T 509	96-00	X	X				
Thunderbird Sport	T309RT	95-	X	X				
Tiger 900	T400	93-01	X			X	X	
Tiger 900	T709	98-	X			X	X	
Trophy 900	T300	92-01	X	X				
Trophy 900	T300E	93-	X	X				
Speed Triple 955	T 595	99-	X	X				
Tiger 955	709EN	01-	X			X	X	
Tiger 1050		07-	X			X		
Speed Triple 1050		05-	X	X				
Trophy 1200	T300	92-	X	X				
Trophy 1200	T300E	93-	X	X				

### Yamaha

DT 125 R	4BL	91-	X		X	X	X	
DT 125 R	3RM	91-	X		X	X	X	
DT 125 R	DE03	98-	X		X	X	X	
DT 125 X	DE06	05-	X		X	X	X	
TW 125	DE01	99-01	X		X	X	X	
TW 125	DE05	02-	X		X	X	X	
XT 125 R	74	05-	X		X	X	X	
XS 400	2A2	82-87	X	X				
SR 500	48T/2J4	78-	X	X				
XT 500	1U6	76-89			X	X	X	
FZ 6, FZ 6S Fazer	RJ07	04-	X					
FZS 600 Fazer	RJ02	98-	X	X				
TT 600	4GV, 4LW	85-03			X	X	X	
TT 600 R	DJ01	98-			X	X	X	
XJ 600 N	3KM		X					
XJ 600 N	3KN	92-	X					
XJ 600 S	4BR/BRA/BRB	91-	X					
XJ 600 S	4LX	93-	X					
XJ 600 N,S	RJ01	97-	X					
XT 600	34L	83-03			X	X	X	
XT 600	43F				X	X	X	
XT 600	55W				X	X	X	
XT 600	1VJ				X	X	X	
XT 600	3AJ				X	X	X	
XT 600	2KF				X	X	X	
XT 600	2NF				X	X	X	
XT 600	3UW	93-			X	X	X	
XT 600	3TB	93-			X	X	X	
XT 600 E	DJ02	98-			X	X	X	
XJ 650	4K0	80-84	X					
MT-03 (660)	RM02	05-	X	X				
XT 660 R, X	DM01	04-			X	X	X	
XTZ 660 Tenere	3YF	91-				X	X	
XTZ 660 Tenere	4BW					X	X	
XTZ 660 Tenere	4MD	93-				X	X	
TDM 850	3VD	96-01	X					
TDM 850	4TX	96-	X					
TDM 900	RN08	02-	X					
XJ 900	31A	85-94	X					
XJ 900	58L		X					
XJ 900	4BB	92-	X					
XJ 900	4KM	94-	X					
FZS 1000 Fazer	RN06	01-	X	X				
FZ1, FZ1S Fazer	RN16	06-	X					
BT 1100 Bulldog	RP05	02-	X	X				
VMX 1200	2EN/2LT/2WE	85-01	X	X				
XJR 1200	4PU	95-98	X	X				
XJR 1300	RP02	99-	X	X				
XJR 1300	RP06/RP10	02-	X	X				



0365

0366

0367

0368

0369

0370

0371

0372

MCL

100-106

150

153

154

155

152

156

157

**Aeon**

Cobra 180

RF3AT72...

X

X

X

**Barossa**

Magna 250

RK4CH250...

X

X

X

Cheetah 250

RK4CH250...

X

X

X

**Bombardier**

DS 650, Baja X

DS 650

00-

X

X

X

**GasGas**

Wild HP 50

Wild HP 50

04-

X

X

X

Wild HP 300

Wild HP 300

03-

X

X

X

Wild HP 450

Wild HP 450

03-

X

X

X

**Kymco**

MXER 150

L2

02-

X

X

X

KXR 250

L3

04-

X

X

X

**Kawasaki**

KFX 50

KFX 50

X

X

X

KFX 250

KFX 250

X

X

X

KFX 300

EF 300 B

03-

X

X

X

KLF 300 Bayou

LF 300 B

88-

X

X

X

KFX 400

AK 47 B

03-

X

X

X

KLF 400 Bayou

LF 400 B

93-99

X

X

X

KFX 700

SV 700 A

04-

X

X

X

**MZ**

ATV 50

ATV 50

X

X

ATV 100

ATV 100

X

X

ATV 150

ATV 150

X

X

**Polaris**

Predator 500

Predator 500

X

X

X

Scrambler 500

Scrambler 500

X

X

X

Trail Boss 330

Trail Boss 330

94-

X

X

X

Trail Blazer 250

Trail Blazer 250

00-

X

X

X

Phoenix 200

Phoenix 200

96-

X

X

X

Predator 90

Predator 90

00-

X

X

X

Predator 50

Predator 50

97-

X

X

X

**Suzuki**

LTZ 250

AJ 4A A

04-

X

X

X

LTF 250

LTF 250

03-

X

X

X

LTF 300

LTF 300

99-01

X

X

X

LTA 400

LTA 400

02-

X

X

X

LTF 400

LTF 400

02-

X

X

X

LTZ 400

AK 47 A

03-

X

X

X

LTA 500

AM 42 A

00-

X

X

X

LTF 500

AM 41 A

X

X

X

LTA 700 X

AP 41 A

X

X

X

King Quad 700

X

X

X

Quadrunner 700

X

X

X

**Yamaha**

YFM 125

YFM 125

X

X

X

YFA 125

YFA 125

X

X

X

YFS 200

YFS 200

X

X

X

YFM 250 Bruin

YFM 250

X

X

X

YFZ 350

YFZ 350

X

X

X

YFM 350 R

YFM 350 R

X

X

X

YFM 400

YFM 400

X

X

X

YFM 450

YFM 450

X

X

X

YFZ 450

YFZ 450

X

X

X

YFM 660 R

YFM 660 R

X

X

X

YFM 700 R

YFM 700 R

X

X

X

**Stahllenker 22 mm**  
**Steel handlebars 22 mm**  
**Guidons acier 22 mm**

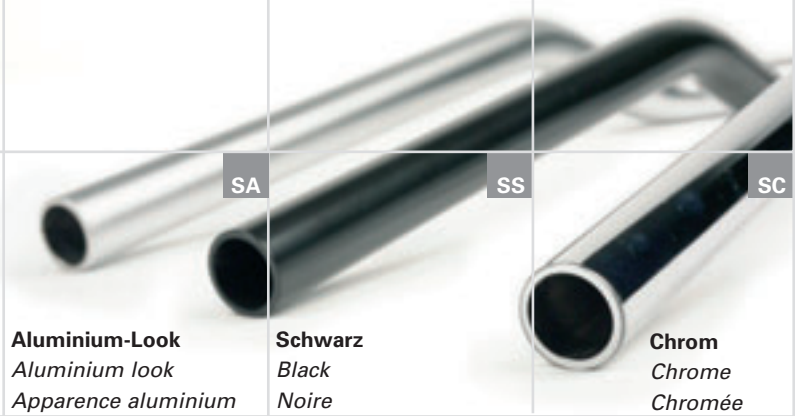

**Aluminium-Look**  
 Aluminium look  
 Apparence aluminium

**Schwarz**  
 Black  
 Noire

**Chrom**  
 Chrome  
 Chromée

**SUPERBIKE**

**Superbike Comfort**



MCL 126 SA SC

**Superbike Sportive**



MCL 128 SA SC

**Superbike Elegance**



MCL 127 SA SC SS

**Speedfighter**



MCL 124 SA SC SS

**CUSTOM**

**Mystik**



MCL 130 SC

**Apehanger**



MCL 137 SC

**Roadstar Wide**



MCL 134 SC

**Dragbar**



MCL 121/122 SC SS

MCL	SC	SA	SS	Typ	A	B	C	D	E	F	Typ
MCL 110	SC		SS	Classic High	830	120	170	140	190		01
MCL 111	SC		SS	Classic Low	755	70	110	60	200		02
MCL 112	SC			Touring High	780	160	220	200	220		03
MCL 113	SC			Touring Low	785	150	180	120	210		04
MCL 121	SC		SS	Dragbar Long	910				330	160	05
MCL 122	SC			Dragbar Medium	810				330	110	06
MCL 124	SC	SA	SS	Speedfighter	865	75	85	80	200		08
MCL 126	SC	SA		Superbike Comfort	745	90	110	140	160		09
MCL 127	SC	SA	SS	Superbike Elegance	770	80	115	100	160		10
MCL 128	SC	SA		Superbike Sportive	760	50	110		210		11
MCL 130	SC			Mystic High	920	140	210	100	300		12
MCL 134	SC			Roadstar Wide	975	85	170	175	220		14
MCL 137	SC			Apehanger	840	250	150	220	260		16

**SC:** Stahl, verchromt  
chrome plated  
acier avec finition chromée

**SA:** Alu-Look  
aluminium look  
acier avec aspect couleur aluminium

**SS:** Stahl, schwarz  
black steel  
acier avec aspect couleur noir

**Die Artikelnummer des Lenkers muß mit dem gewünschten Kürzel versehen werden.**

*Add the required suffix to the part number.*

*Compléter la référence du guidon avec le code couleur souhaité.*



MCL 217 SA



MCL 217 SC

2 Stück  
2 pièces  
2 pièces



MCL 217 SS

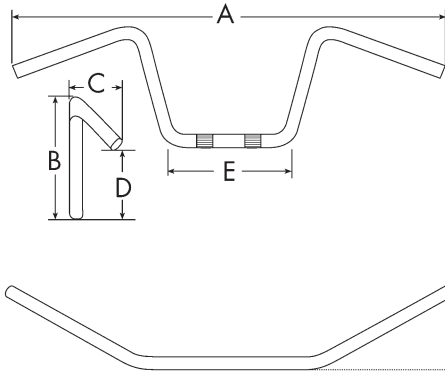

**Jetzt neu mit ABE.  
Kein TÜV  
mehr nötig!**



**TOURING**

Classic High



MCL 110 SC

Classic Low



MCL 111 SC

Touring High



MCL 112/113 SC



MCL 110	MCL 111	MCL 112	MCL 113	MCL 121	MCL 122	MCL 124	MCL 126	MCL 127	MCL 128	MCL 130	MCL 137
Typ 01	Typ 02	Typ 03	Typ 04	Typ 05	Typ 06	Typ 08	Typ 09	Typ 10	Typ 11	Typ 12	Typ 16

### Aprilia

650	Pegaso	GA/MX/ML	93-		X					X	X	X							
-----	--------	----------	-----	--	---	--	--	--	--	---	---	---	--	--	--	--	--	--	--

### BMW

R 850	R	BMW 259	93-00		X							X	X						
R 850	R	R21	01-		X							X	X						
R 1100	R	BMW 259	93-00		X							X	X						
R 1150	R	R21	01-	X	X	X	X					X	X						

### Ducati

400	Monster	M3	98-01		X							X	X	X					
600	Monster	M/M3	94-01		X							X	X	X					
620	Monster	M4	02-		X							X	X	X					
750	Monster	M/M4	97-02		X							X	X	X					
800	Monster	M4	03-		X							X	X	X					
SR2 800	Monster	M4	05-		X							X	X	X					
900	Monster	M/M2/M4	94-		X							X	X	X					
1000	Monster i.e.	M4	03-		X							X	X	X					

### Honda

CA 125	Rebel	JC24/JC26	95-97	X		X	X	X	X										X	X
VT 125	C Shadow	JC125/JC31	99-	X		X	X	X	X										X	X
XL 125	Varadero	JC 32	01-	X	X	X	X	X					X	X						
CB 250	Two Fifty	MC 26	92-	X	X	X	X					X	X	X						
CMX 250	Rebel	MC13B	96-	X	X	X	X												X	X
CB 400	N	CM400N	78-82	X	X	X	X					X	X	X						
CB 500		PC 26/PC32	94-03	X		X	X						X	X						
CBF 500		PC 39	04-	X	X	X	X					X	X	X						
CX 500		CX500	79-81	X	X	X	X					X	X	X						
CX 500	C	PC01		X		X		X	X										X	X
CX 500	E	PC06		X	X	X						X	X	X						
CX 500	T	PC03			X							X	X	X				X		
CB 600	Hornet	PC34/PC36	00-	X	X	X	X					X	X	X						
CBF 600		PC 38	04-	X		X	X						X	X						
NT 650	Deauville	RC 47	98-	X	X	X	X						X	X						
NTV 650		RC 33	88-97	X	X	X	X					X	X	X						
NX 650	Dominator	RD 08	88-	X	X	X	X						X	X						
SLR 650		RD 09	97-98	X	X	X	X					X	X	X						
XL 650	Transalp	RD 10	00-	X	X	X	X						X	X						
CB 750	Seven fifty	RC 42	92-03	X	X	X	X					X	X	X						
XRV 750	Africa Twin	RD04/RD07	89-03	X	X	X	X						X	X						
CB 900	Hornet	SC 48	02-	X	X	X	X					X	X	X						
CB 1000	Big	SC 30	92-96	X	X	X	X					X	X	X						
CBF 1000			06-	X		X	X						X	X						
GL 1000		GL1	75-81	X	X	X	X					X	X	X						
XL 1000	Varadero	SD 01	99-	X	X	X	X						X	X						
CB 1100	X-4	SC 54	03-	X	X	X	X					X	X	X						

### Kawasaki

ER-5 500		ER500A	96-	X	X	X	X					X	X	X						
ZR 550	Zephyr	KZ550A	83-90	X	X	X	X	X	X	X	X	X	X	X					X	X
ZR 550	Zephyr	ZR550B	91-92	X	X	X	X	X	X	X	X	X	X	X					X	X
ZR 550	Zephyr	ZR550B	93-95	X	X	X	X	X	X	X	X	X	X	X					X	X
ZR 550	Zephyr	ZR550B	96-99	X	X	X	X	X	X	X	X	X	X	X					X	X
ZL 600	Eliminator	ZL600B	95-97	X	X	X	X	X	X	X	X	X	X	X					X	X
ER-6 600		FJN	05-	X	X	X	X					X	X	X						
Z 750		ZR750J	04-	X	X	X	X					X	X	X						
Z 750	S	ZR750J	05-	X	X	X	X					X	X	X						
ZR 750	Zephyr	ZR750D	96-99	X	X	X	X	X	X	X	X	X	X	X					X	X
ZR 750	Zephyr	ZR 750C	91-99	X	X	X	X	X	X	X	X	X	X	X					X	X
ZR-7 750		ZR750F	99-	X	X	X	X					X	X	X						
ZR-7 750	S	ZR750F	01-	X	X	X	X					X	X	X						
KLV 1000		WVBS	04-	X	X	X	X					X	X	X						
Z 1000		ZRT00A	03-		X	X	X					X	X	X						
ZR 1100	Zephyr	ZRT10A/B	91-96	X	X	X	X	X	X	X	X	X	X	X					X	X
ZR 1100	Zephyr	ZRT10B	97	X	X	X	X	X	X	X	X	X	X	X					X	X
ZR 1100	Zephyr	ZRT 10A	91-		X							X	X	X						
ZRX 1100	R	ZRT10C	97-00	X	X	X	X					X	X	X					X	
ZRX 1100	S	ZRT10C	97-00	X	X	X	X					X	X	X					X	
ZRX 1200	R/S	ZRT20A	01-	X	X							X	X	X					X	

### Suzuki

VL 125	Intruder LC	VVA4	02-	X		X	X	X	X	X									X	X
VL 125	Intruder LC	A4	99-01	X		X	X	X	X	X									X	X
GZ 250	Marauder	AR	00-	X		X	X	X	X	X									X	X
VL 250	Intruder	VVA5	00-	X	X	X	X	X	X	X				X	X				X	X
DR 350		SK42B	90-97		X								X	X						
DR-Z 400	S	BE, BF	00-		X								X	X						
DR-Z 400	SM	WVBC	05-06		X								X	X						
GS 500		GM51B	89-	X	X	X	X						X	X						





### Suzuki

GSR 600		WVB9	06-	x	x	x			x	x	x	x
GSF 600	Bandit	GN77B/WVA8	95-00		x				x	x	x	x
GSF 650	Bandit	WVB5	05-		x				x	x	x	x
DL 650	V-Strom	WVB1	04-	x	x				x	x	x	
DR 650		SP42B – SP46B	90-		x				x	x		
SV 650	N	AV/WVBY	99-		x				x	x	x	
XF 650	Freewind	AC	97-		x				x	x	x	
GSX 750		AE	98-01	x	x		x	x	x	x	x	
DR 800		SR42/SR43B	92-		x				x	x		
DL 1000	V-Strom	WVBS	02-	x	x				x	x	x	
SV 1000		WVBX	03-		x				x	x	x	
GSX 1100	G	GV74A	91-96	x	x				x	x	x	x
GSF 1200	Bandit	GV75A/WVA9/WVCB	96-06		x				x	x	x	x
GSX 1200		A3	99-00	x	x				x	x	x	x
GSF 1250		WVCH	07-		x				x	x	x	x
GSX 1400		WVBN	01-	x	x				x	x	x	x

### Triumph

900	Bonneville	T100	04-	x	x				x	x	x	x
900	Scrambler		06-	x	x				x	x	x	x
900	Speed Triple	T 509	96-00		x				x	x	x	x
900	Tiger	T400	93-01		x				x	x		
900	Tiger	T709	98-		x				x	x		
900	Trophy	T300	92-01		x				x	x	x	
955	Speed Triple	T 595	99-		x				x	x	x	
955	Tiger	709EN	01-		x				x	x		
1050	Speed Triple		05-									
1200	Trophy	T300	92-		x				x	x	x	
1200	Trophy	T300E	93-		x				x	x	x	
	Thunderbird Sport	T309RT	95-		x				x	x	x	

### Yamaha

XV 125	S, Virago	5AJ	97-	x		x	x	x	x			x	x
XVS 125	Drag Star	VE01	00-	x		x	x	x	x			x	x
XV 250	Virago	3LS, 3LW/VG01	89-	x		x	x	x	x			x	x
XVS 250	Drag Star	VG03	01-	x		x	x	x	x			x	x
XS 400		2A2	82-87	x									
XV 400	Virago		88-	x	x	x	x	x	x			x	x
SR 500		48T/2J4	78-	x	x	x	x		x	x	x		x
XV 500	26R	83-		x		x	x	x	x			x	x
XV 535	DX Virago	VJ01	98-03	x		x	x	x	x			x	x
XV 535	SE, N, H	3BR, 2YL	88-	x		x	x	x	x			x	x
XV 535	Virago	2YL, 4KU3, 3BTV	93-94	x		x	x	x	x			x	x
XV 535	Virago	3BR	95-97	x		x	x	x	x			x	x
FZ6 600		RJ07	04-		x				x	x	x	x	
FZS 600	Fazer	RJ02	98-		x				x	x	x	x	
XJ 600	N	3KM		x	x				x	x	x		
XJ 600	N	3KN	92-	x	x				x	x			
XJ 600	S	4BR	91-	x	x				x	x			
XJ 600	S	4BRA	91-	x	x				x	x			
XJ 600	S	4BRB	91-	x	x				x	x			
XJ 600	S	4LX	93-	x	x				x	x			
XJ 600	N,S	RJ01	97-	x	x				x	x			
XJ 650		4K0	80-84	x	x				x	x			
XV 750		4FY	89-92	x		x	x	x	x			x	x
XV 750	SE	5G5, 5K4	81-82	x		x	x	x	x			x	x
XV 750	Virago	4PW	94-98	x		x	x	x	x			x	x
TDM 850		3VD	96-01	x	x				x	x	x		
TDM 850		4TX	96-	x	x				x	x	x		
TDM 900		RN08	02-	x	x				x	x	x		
XJ 900		31A	85-94	x	x				x	x	x		
XJ 900		58L		x	x				x	x	x		
XJ 900		4BB	92-	x	x				x	x	x		
XJ 900		4KM	94-	x	x				x	x	x		
FZS 1000	Fazer	RN06	01-		x				x	x	x	x	
XV 1000	SE	23W	83-85	x		x	x	x	x			x	x
XV 1000	TR1	5A8, 19T	81-	x		x	x	x	x			x	x
XV 1000	Virago	2AE	86-87	x		x	x	x	x			x	x
BT 1100	Bulldog	RP05	02-		x				x	x	x		
XV 1100	Virago	3LP	86-93	x		x	x	x	x			x	x
XV 1100	Virago	3LP	94-98	x		x	x	x	x			x	x
XV 1100	Virago	3LP	99	x		x	x	x	x			x	x
VMX 1200		2EN	85-01		x				x	x	x		
VMX 1200		2LT			x				x	x	x		
VMX 1200		2WE			x				x	x	x		
XJR 1200		4PU	95-98		x				x	x	x		
XJR 1300		RP02	99-		x				x	x	x		
XJR 1300		RP06	02-04		x				x	x	x		
XJR 1300		RP10	05-		x				x	x	x		

## Stahllenkler 25,4 mm Steel handlebars 25,4 mm Guidons acier 25,4 mm

- attraktives Design für stilgerechte Optik
  - gutes Lenkverhalten durch ausgereifte Formen
  - individuelles Outfit beginnt schon beim Lenkerumbau
  - Lenkerwechsel ermöglicht bequemere Sitzposition
  - hochwertigste Oberflächenbehandlungen
  - 3-fach-Spezialbeschichtung verhindert Korrosion
  - keine matten Chromstellen an den Biegepunkten
  - Stahlrohre von hoher Güte
- *attractive design adds style*
  - *good steering response through fully-developed design*
  - *individualisation begins with the handlebars*
  - *changing the handlebar allows a more comfortable sitting position*
  - *top quality surface treatments*
  - *triple special coating prevents corrosion*
  - *no matt chrome on the bends*
  - *high quality steel tubes*
- *design attirant et donnant du style*
  - *bon maintien du guidon grâce à des formes sophistiquées*
  - *une apparence personnalisée commence d'abord par la forme du guidon*
  - *le changement de guidon permet une position assise plus confortable*
  - *traitement de surface supérieur*
  - *3 couches spéciales anti-corrosion*
  - *pas de marques de chrome mat aux points de flexion*
  - *tubes en acier de la meilleure qualité*

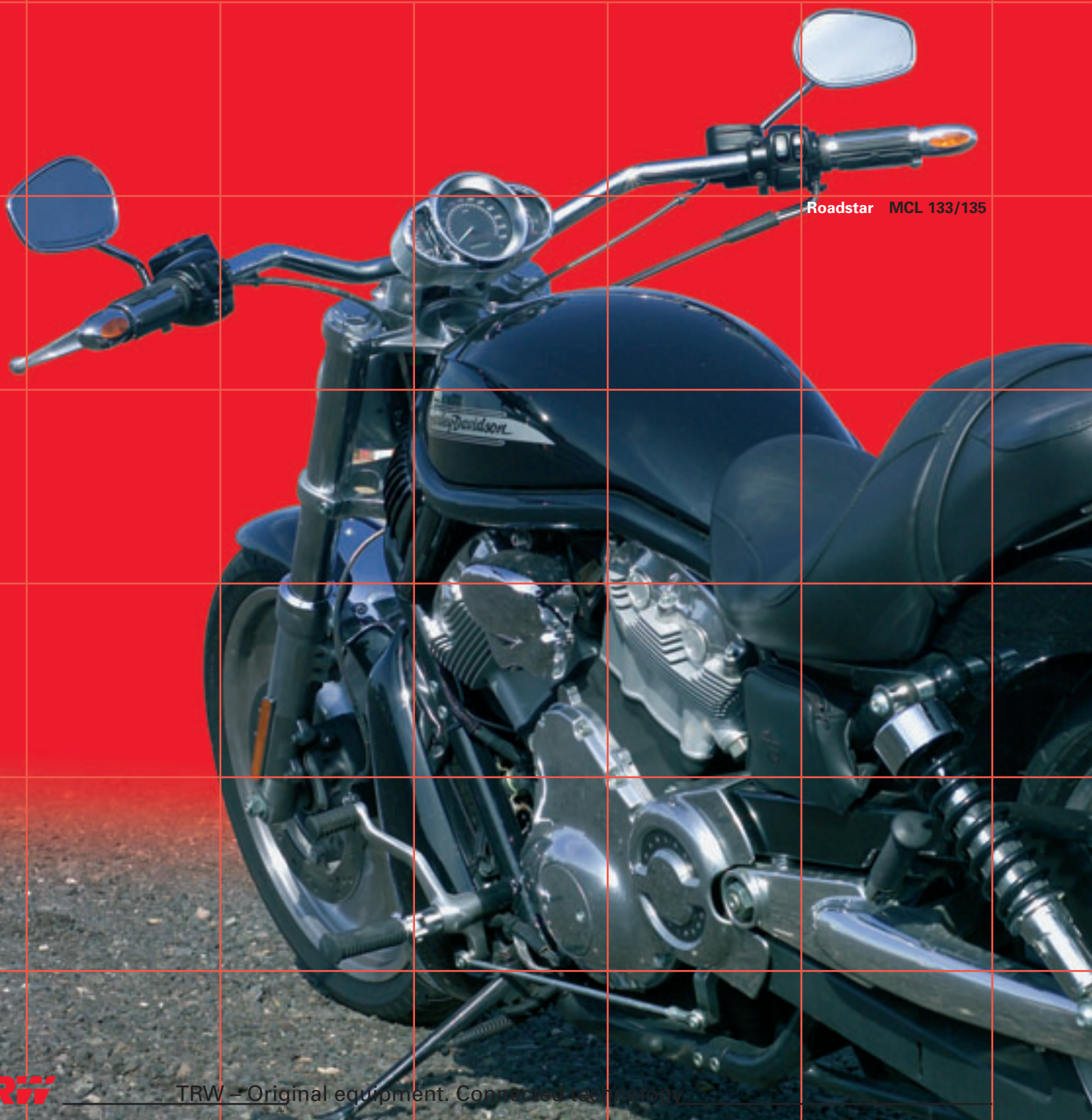

Roadstar MCL 133/135

Dragbar



MCL 120  
MCL 123

Jetzt neu  
mit ABE.  
Kein TÜV  
mehr nötig!

Speedfighter



MCL 125

Roadstar



MCL 133  
MCL 135

Flyerbar



MCL 132

Apehanger



MCL 136

Mystik



MCL 131

**Stahllenker 25,4 mm**  
**Steel handlebars 25,4 mm**  
**Guidons acier 25,4 mm**



**Jetzt neu mit ABE.**  
**Auch für Harley Davidson!**

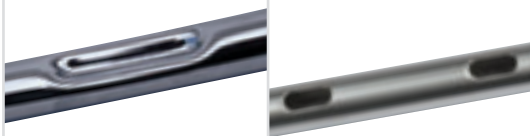

**Kabelkerbe (KK)**  
*Cable indent*  
*Avec nervures pour les câbles*

**Kabelbohrung im Alu-Look**  
*Cable openings in aluminium look*  
*Avec trous pour le passage des câbles*

**Für nicht aufgeführte Motorrad-Modelle gilt das TÜV-Gutachten.**

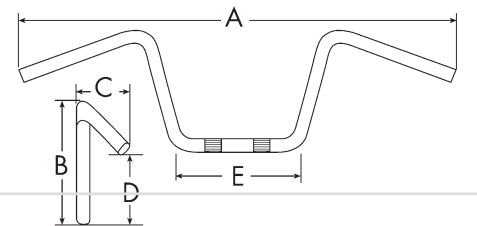

**Die Art.-Nr. des Lenkers muss mit dem gewünschten Kürzel versehen werden.**  
*Add the required suffix to the part number.*  
*Compléter la référence du guidon avec le code couleur souhaité.*

- SC:** **Stahl, verchromt**  
*chrome plated*  
*acier avec finition chromée*
- SA:** **Alu-Look**  
*aluminium look*  
*acier avec aspect couleur aluminium*
- SS:** **Stahl, schwarz**  
*black steel*  
*acier avec aspect couleur noir*
- AKB:** **Alu-Look mit Kabelbohrungen**  
*aluminium look with cable openings*  
*acier avec les trous pour câbles percés et aspect couleur aluminium*

- AKK:** **Alu-Look mit Kabelkerben**  
*aluminium look with cable indent*  
*acier avec nervures pour passage de câble et aspect couleur aluminium*
- CKB:** **Stahl, verchromt mit Kabelbohrungen**  
*chrome plated with cable openings*  
*acier avec les trous pour câbles percés avec finition chromée*
- CKK:** **Stahl, verchromt mit Kabelkerben**  
*chrome plated with cable indent*  
*acier avec nervures pour passage des câbles avec finition chromée*

Lucas									Typ		
MCL	Typ	Material	SA	SC	A	B	C	D	E	F	Typ
MCL 120		CKB	CKK	SA	SC	910			330	160	05
MCL 123	AKK		CKK	SA	SC	810			330	110	06
MCL 125	AKK		CKK	SA	SC	870	75	85	80	200	08
MCL 131			CKK	SA	SC	920	160	210	110	300	12
MCL 132		CKB	CKK	SA	SC	980	60	180	30	230	13
MCL 133			CKK	SA	SC	980	85	170	175	220	14
MCL 135	AKK		CKK		SC	920	170	160	300	240	15
MCL 136			CKK	SA	SC	930	240	180	210	260	16



**MCL 120**  
Typ 05  
Dragbar  
Long

**MCL 123**  
Typ 06  
Dragbar  
Medium

**MCL 125**  
Typ 08  
Speedfighter

**MCL 131**  
Typ 12  
Mystik High

**MCL 132**  
Typ 13  
Flyerbar

**MCL 133**  
Typ 14  
Roadstar  
Wide

**MCL 135**  
Typ 15  
Roadstar  
Medium

**MCL 136**  
Typ 16  
Apehanger

## Harley-Davidson

883	Sportster 883	XL	01-06	X	KK	KK						KK
883	Sportster 883	XLH	89-00	X	KK	KK						KK
1000	Sportster 1000	XLS	79-81	X	X	X						X
1000	Sportster 1000	XLS	82-85	KK	KK	KK						KK
1000	Sportster 1000	XLH	72-81	X	X	X						X
1000	Sportster 1000	XLH	82-85	KK	KK	KK						KK
1000	Sportster 1000	XLX	83-85	KK	KK	KK						KK
1200	Sportster 1200	XL	96-06	KK	KK	KK						KK
1200	Sportster 1200	XLH	89-99	KK	KK	KK						KK
1200	Electra Glide	FLH	65-77	X	X	X	X	X	X	X	X	X
1340	Electra Glide	FLH	78-81	X	X	X	X	X	X	X	X	X
1340	Electra Glide	FLH	82-84	KK	KK	KK						KK
1340	Fat Boy	FLSTF	90-99	KK	KK	KK	KK	KK	KK	KK	KK	KK
1450	Fat Boy	FLSTF	00-03	KK	KK	KK	KK	KK	KK	KK	KK	KK
1450	Fat Boy	FLSTFI	01-06	KK	KK	KK	KK	KK	KK	KK	KK	KK
1340	Heritage Softtail	FLST	87-90	KK	KK	KK	KK	KK	KK	KK	KK	KK
1340	Sport Glide	FXRT	83-92	KK	KK	KK	KK	KK	KK	KK	KK	KK
1200	Low Rider	FXS	77-79	X	X	X	X	X	X	X	X	X
1340	Low Rider	FXS	77-81	X	X	X	X	X	X	X	X	X
1340	Low Rider	FXS	82-84	KK	KK	KK	KK	KK	KK	KK	KK	KK
1340	Low Rider	FXSB	82-85	KK	KK	KK	KK	KK	KK	KK	KK	KK
1340	Softtail	FXST	84-90	KK	KK	KK	KK	KK	KK	KK	KK	KK
1450	Softtail	FXSTI	04-05	KK	KK	KK	KK	KK	KK	KK	KK	KK
1340	Softtail Custom	FXSTC	86-98	KK	KK	KK	KK	KK	KK	KK	KK	KK
1340	Springer Softtail	FXSTS	88-99	KK	KK	KK	KK	KK	KK	KK	KK	KK
1450	Springer Softtail	FXSTS/I		KK	KK	KK	KK	KK	KK	KK	KK	KK
1340	Wide Glide	FXWG	80-81	X	X	X	X	X	X	X	X	X
1340	Wide Glide	FXWG	82-85	KK	KK	KK	KK	KK	KK	KK	KK	KK
1340	Night Train/ Bad Boy	FXSTB	95-99	KK	KK	KK	KK	KK	KK	KK	KK	KK
1450	Night Train	FXSTB	00-04	KK	KK	KK	KK	KK	KK	KK	KK	KK
1450	Night Train	FXSTB/I	05-	KK	KK	KK	KK	KK	KK	KK	KK	KK
1450	Softtail Deuce	FXSTD	00-03	KK	KK	KK	KK	KK	KK	KK	KK	KK
1450	Softtail Deuce	FXSTDI	01-04	KK	KK	KK	KK	KK	KK	KK	KK	KK

## Kawasaki

VN	800	VN800A/B	95-99	X	X	X	X	X	X	X	X	X
VN	800	Classic	VN800B	96-	X	X	X	X	X	X	X	X
VN	800	Drifter	VN800C	99-04	X	X	X	X	X	X	X	X
VN	1500		VNT50A	88-93	X	X	X	X	X	X	X	X
VN	1500	Classic	VNT50D	96-00	X	X	X	X	X	X	X	X
VN	1500	Classic Fi	VNT50N	00-	X	X	X	X	X	X	X	X+
VN	1500	Classic Tourer Fi,	VNT50G	98-	X	X	X	X	X	X	X	X
VN	1500	Drifter	VNT50J	99-	X	X	X	X	X	X	X	X
VN	1500	Mean Streak	VNT50P	02-	X	X	X	X	X	X	X	X
VN	1500	SE	VNT50B	88-93	X	X	X	X	X	X	X	X
VN	1500	SE	VNT50C	94-95	X	X	X	X	X	X	X	X
VN	1600	Classic	VNT60A		X	X	X	X	X	X	X	X
VN	1600	Classic	VNT60A	03-	X	X	X	X	X	X	X	X
VN	1600	Mean Streak	VNT60B	04	X	X	X	X	X	X	X	X
VN	1600	Mean Streak		05-	X	X	X	X	X	X	X	X
VN	2000			04-	X	X	X	X	X	X	X	X

## Suzuki

M	800	Intruder		X	X	X	X	X	X	X	X	X
VL	800	Intruder LC Volusia	WVBM	X	X	X	X	X	X	X	X	X
VZ	800	Marauder	AF	97-03	X	X	X	X	X	X	X	X
VS	1400	Intruder	VX51L/LD	87-	X	X	X	X	X	X	X	X
C	1500	Intruder		05-	X	X	X	X	X	X	X	X
VL	1500	Intruder	WVAL	02-	X	X	X	X	X	X	X	X
VL	1500	Intruder	AL	98-01	X	X	X	X	X	X	X	X
M	1600	Intruder		05-	X	X	X	X	X	X	X	X
VZ	1600	Marauder		04-	X	X	X	X	X	X	X	X

## Triumph

	800	America		02-	X	X	X	X	X	X	X	X
	900	Speedmaster		05-	X	X	X	X	X	X	X	X
	2300	Rocket III		04-				X	X	X	X	X

## Yamaha

XVS	650	A Drag Star classic	VM02/VM03	98-	X	X	X	X	X	X	X	X
XVS	650	Drag Star	4XR	97-04	X	X	X	X	X	X	X	X
XVS	1100	Drag Star	VP05	99-00	X	X	X	X	X	X	X	X
XVS	1100	Drag Star Classic	VP05	00-	X	X	X	X	X	X	X	X
XVZ	1300	A Royale Star	4YP	96-00	X	X	X	X	X	X	X	X
XVZ	1300	AT,Royal Star Tour	4YP	97-00	X	X	X	X	X	X	X	X
XVZ	1300	Royal Star Boulevard	VP09	99-	X	X	X	X	X	X	X	X
XVZ	1300	TF Royal Star Venture	VP09	99-	X	X	X	X	X	X	X	X
XVZ	1300	Vent. Royale	3JS	86-95	X	X	X	X	X	X	X	X
XV	1600	A Wild Star	VP08	99-	X	X	X	X	X	X	X	X
XV	1700	PC Road Star Warrior	VP14		X	X	X	X	X	X	X	X

## Gabelbrücken mit TÜV-Gutachten

Triple trees

Té de fourche



Durch schräge Bockchen kann bei vielen Modellen das Abschneiden von Verkleidung oder Scheibe vermieden werden.

*The sloping riser helps to avoid altering the body work.*

*Ces cales inclinées peuvent s'adapter à plusieurs formes de pare brises ou de carènes sans modification.*

- Aluminium-Gabelbrücke CNC-gefräst
- ausgefräste Unterseite bewirkt gute Kräfteverteilung, hohe Gewichtsersparnis
- bessere Kraftübertragung und höhere Steifigkeit als Gussbrücken oder Adapterplatten
- problemlose Lenkerbefestigung von oben
- kein Spiel am Steuerkopfrohr
- bei einigen Modellen sind Verkleidungsänderungen oder kürzere Scheibe nötig
- gesichertes Zündschloss
- Fachleuten empfehlen wir die Begrenzung des Lenkeinschlags

- aluminium CNC-manufactured triple trees
- recessed underside results in improved load distribution, optimum weight savings
- improved power transmission and greater rigidity than cast bridges or adapter plates
- trouble-free handlebar mounting from above
- no movement at the steering head tube
- some adjustment may be necessary to the panelling
- we recommend that the steering lock is set by a professional mechanic

- té aluminium supérieur de fourche réalisé en commande numérique
- l'usinage et le renforcement réalisés sous le té augmentent la rigidité et en diminuent le poids
- l'amélioration de la rigidité est bien supérieure au té en aluminium moulé ou autre ensemble adaptable
- fixation des pontets de guidon par le dessus
- pas de modification à apporter sur le tube de direction
- quelques petits ajustements peuvent être requis au niveau du tableau de bord
- nous vous recommandons de faire changer l'anti-vol de direction par un professionnel
- nous recommandons de régler les butées de direction

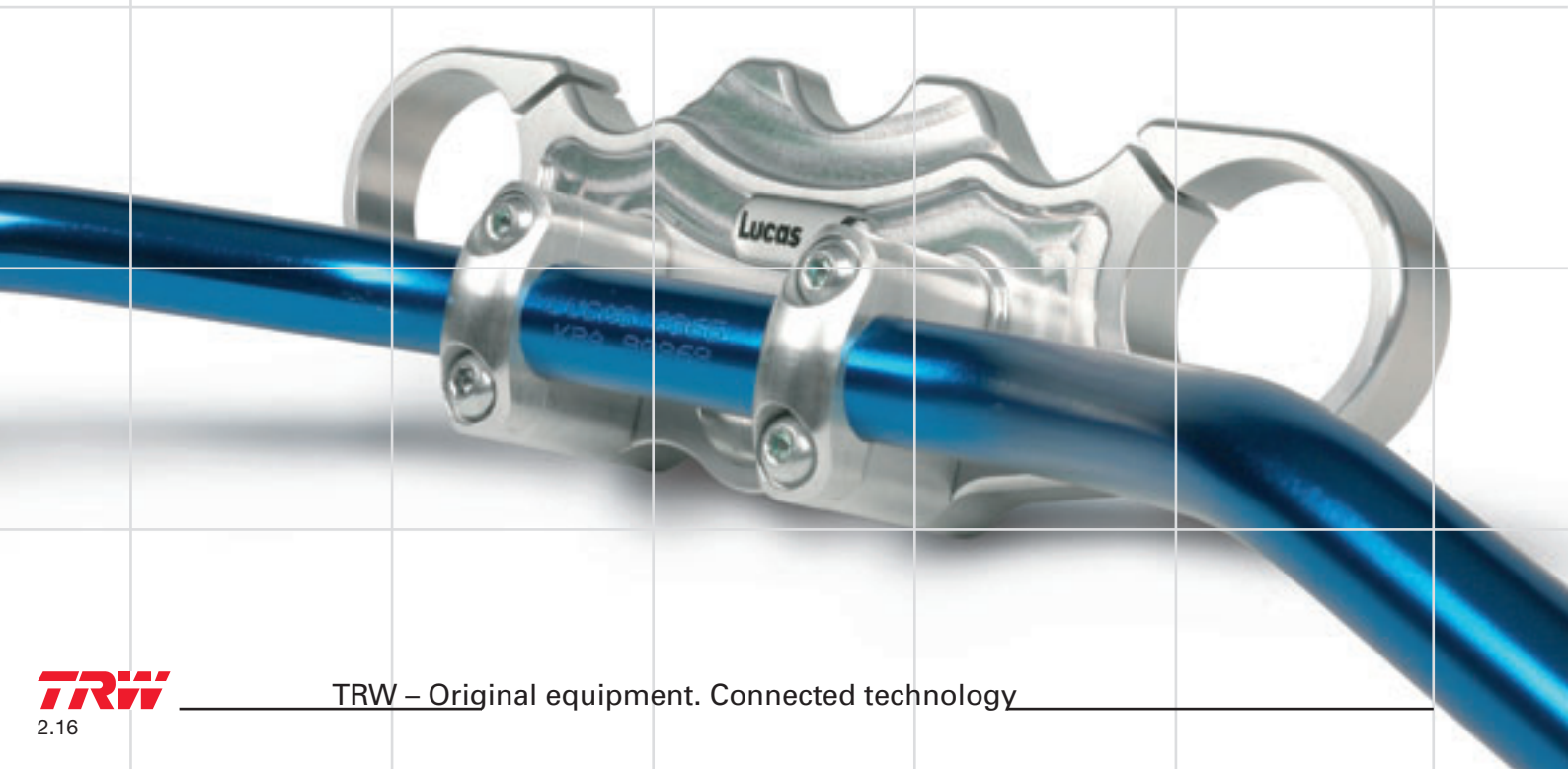



**Halter für Flüssigkeitsbehälter**  
*Bracket for fluid reservoir*  
*Support de réservoir de liquide*



**verlängerte Stahlflex-Brems- und -Kupplungsleitungen**  
*Extended steel braided brake and clutch hoses*  
*Extension de flexibles de freins et d'embrayages*



**verlängerter Kupplungszug**  
*Extended clutch cable*  
*Extension de cable d'embrayage*



**Hupenverlängerung**  
*Horn extension*  
*Cable d'extension pour avertisseur*



**Verkleidungshalter aus Aluminium**  
*Aluminium fairing holder*  
*Support de carène en aluminium*



**MCG 600**



**MCZ 530**



**MCZ 531**

**Minibehälter, Kunststoff / Aluminium**  
*Mini style reservoir, plastic / aluminium*  
*Réservoir de liquide, plastique / aluminium*



**MCZ 531 S**  
**MCZ 531 C**



**MCZ 530 S**  
**MCZ 530 C**

**schräge Böckchenunterteile zum Nachrüsten**  
*Sloping riser base for retro fitting*  
*Cales à insérer entre les supports du guidon pour une position de conduite plus adaptée*

**2 Stück**  
*2 pieces*  
*2 pièces*

S = schwarz, C = chrom  
 S = black, C = chrome  
 S = noire, C = chromée





## Suzuki

GSXR	750	GR7AB	90-91	<b>MCG 547 S</b>	<sup>1)</sup>	<b>MCH 32</b>	<b>MCH 85</b>						
GSXR	750	W GR7BB/BC	92-93	<b>MCG 540 S</b>	<sup>1)</sup>	<b>MCH 32</b>	<b>MCH 85</b>						
GSXR	750	W GR7BB	94-95	<b>MCG 546 S</b>	<sup>1)</sup>		<b>MCH 41</b>					<b>MCG 601</b>	
GSXR	750	W GR7DB/DC	96-97	<b>MCG 541 S</b>	<sup>1)</sup>		<b>MCH 41</b>				<b>MCG 541VH</b>	<b>MCG 601</b>	
GSXR	750	W GR7DB	98-99	<b>MCG 541 S</b>	<sup>1)</sup>		<b>MCH 41</b>				<b>MCG 541VH</b>	<b>MCG 601</b>	
GSXR	750	W WVBD	00-03	<b>MCG 584 S</b>	<sup>2)</sup>		<b>MCH 44</b>					<b>MCG 601</b>	
GSXR	750	WVVB3	04-05	<b>MCG 589 S</b>		<b>MKK201<sup>5)</sup></b>	<b>MCH 73</b>				<b>MCG 589VH</b>	<b>MCG 607</b>	
GSXR	1000	WVBL	01-02	<b>MCG 584 S</b>	<sup>2)</sup>		<b>MCH 44</b>					<b>MCG 601</b>	
GSXR	1000	WVVBZ	03-04	<b>MCG 586 S</b>		<b>MCH 77 BB</b>							
SV	1000	S WVVBX	03-	<b>MCG 587 S</b>		<b>MCH 77 BB</b>	<b>MCH 84</b>	<b>MCH 276 V1</b>					
GSXR	1100	GU74C/D	86-88	<b>MCG 548 S</b>	<sup>1)</sup>	<b>MCH 50</b>					<b>MCH 90</b>		
GSXR	1100	GV73A/B/C/E	89-90	<b>MCG 549 S</b>	<sup>1)</sup>	<b>MCH 62</b>					<b>MCH 94</b>		
GSXR	1100	UPS GV73B/C/E	90-92	<b>MCG 542 S</b>	<sup>1)</sup>	<b>MCH 33</b>	<b>MCH 86</b>	<b>MCH 94</b>					
GSXR	1100	W GU75A-E	93-94	<b>MCG 545 S</b>	<sup>1)</sup>		<b>MCH 42</b>	<b>MCH 95</b>					
GSF	1200	Bandit GV75A	96-00	<b>MCG 543 S</b>		<b>MCH 57</b>	<b>MCH 87</b>	<b>MCH 97</b>					
GSXR	1300	Hayabusa WVA1	99-	<b>MCG 580 S</b>	<sup>2)</sup>		<b>MCH 88</b>	<b>MCH 95</b>					

## Triumph

750	Trident	T300C	91-	<b>MCG 560 T</b>		<b>MCH 32</b>					<b>MCH 96</b>		
900	Daytona	T300B/D	91-	<b>MCG 561 T</b>	<sup>3)</sup>	<b>MCH 32</b>					<b>MCH 96</b>		
900	Speed Triple	T300B	94-95	<b>MCG 562 T</b>		<b>MCH 62</b>					<b>MCH 94</b>		
900	Speed Triple	T509	96-	<b>MCG 562 T</b>		<b>MCH 62</b>					<b>MCH 94</b>		
900	Sprint	T300A	91-93	<b>MCG 560 T</b>	<sup>3)</sup>	<b>MCH 32</b>					<b>MCH 96</b>		
900	Sprint	T300A	94-	<b>MCG 560 T</b>	<sup>3)</sup>	<b>MCH 32</b>					<b>MCH 96</b>		
900	Trident	T300C	91-	<b>MCG 560 T</b>		<b>MCH 32</b>					<b>MCH 96</b>		
900	Trophy	T300E	91-	<b>MCG 560 T</b>	<sup>3)</sup>	<b>MCH 32</b>					<b>MCH 96</b>		
955	Daytona	T595	97-98	<b>MCG 563 T</b>								<b>MCG 601</b>	
955	i, Daytona	T595	99-00	<b>MCG 563 T</b>								<b>MCG 601</b>	
1200	Trophy	T300	91-	<b>MCG 560 T</b>		<b>MCH 32</b>					<b>MCH 96</b>		

## Yamaha

FZR	600	3HE/3HF	89-93	<b>MCG 556 Y</b>	<sup>1)</sup>			<b>MCH 055</b>					
FZR	600	3RG	89-93	<b>MCG 556 Y</b>	<sup>1)</sup>	<b>MCH 50</b>	<b>MCH 084</b>						
FZR	600	3RH	89-93	<b>MCG 556 Y</b>	<sup>1)</sup>	<b>MCH 50</b>	<b>MCH 084</b>						
FZR	600	R 4FH	93-95	<b>MCG 550 Y</b>	<sup>1)</sup>		<b>MCH 021</b>					<b>MCG 601</b>	
FZR	600	R 4JH	94-95	<b>MCG 550 Y</b>	<sup>1)</sup>		<b>MCH 051</b>					<b>MCG 601</b>	
FZR	600	R 4MH/4MM	94-95	<b>MCG 550 Y</b>	<sup>1)</sup>		<b>MCH 51</b>					<b>MCG 601</b>	
YZF	600	Thunder Cat 4TV/4WD	96-	<b>MCG 555 Y</b>	<sup>1)</sup>	<b>MCH 50</b>	<b>MCH 84</b>					<b>MCG 608</b>	<b>MCG 603</b>
YZF	600	R6 RJ03	99-02	<b>MCG 574 Y</b>	<sup>2)</sup>		<b>MCH 23</b>	<b>MKK 108</b>				<b>MCG 608</b>	<b>MCG 603</b>
YZF	600	R6 RJ05	03-	<b>MCG 576 Y</b>	<sup>2)</sup>		<b>MCH 47</b>	<b>MKK 109</b>				<b>MCG 607</b>	
FZ	750	Genesis 3KT/2KK	89-91	<b>MCG 572 Y</b>		<b>MCH 62</b>	<b>MCH 58</b>						
YZF	750	R 4HN	93-96	<b>MCG 551 Y</b>	<sup>1)</sup>		<b>MCH 52</b>	<b>MCH 96</b>	<b>MCG 551VH</b>		<b>MCG 601</b>		<b>MCG 603</b>
YZF	750	SP 4HT	95-96	<b>MCG 551 Y</b>	<sup>1)</sup>		<b>MCH 52</b>	<b>MCH 96</b>	<b>MCG 551VH</b>		<b>MCG 601</b>		<b>MCG 603</b>
TRX	850	4UN	96-	<b>MCG 554 Y</b>	<sup>1)</sup>		<b>MCH 56</b>				<b>MCG 601</b>		<b>MCG 603</b>
FZR	1000	UPS 3LE/LF/LG/LK	91-93	<b>MCG 552 Y</b>	<sup>1)</sup>	<b>MCH 62</b>	<b>MCH 23</b>	<b>MCH 96</b>	<b>MCG 552VH</b>				
FZR	1000	UPS 3LE/LF/LG/LK	94-95	<b>MCG 552 Y</b>	<sup>1)</sup>		<b>MCH 54</b>	<b>MCH 94</b>	<b>MCG 552VH</b>				
YZF	1000	R1 RN01	98-00	<b>MCG 570 Y</b>	<sup>1)</sup>		<b>MCH 63</b>	<b>MKK 107</b>				<b>MCG 608</b>	
YZF	1000	R1 RN04	01	<b>MCG 570 Y</b>	<sup>1)</sup>		<b>MCH 63</b>	<b>MKK 107</b>				<b>MCG 608</b>	
YZF	1000	R1 RN09	02-03	<b>MCG 575 Y</b>			<b>MCH 63</b>	<b>MKK 106</b>				<b>MCG 607</b>	
YZF	1000	R1 RN12	04-06	<b>MCG 577 Y</b>	<sup>1)</sup>	<b>MKK200<sup>5)</sup></b>	<b>MCH 66</b>	<b>MKK 110</b>				<b>MCG 607</b>	<b>MCG 603</b>
FJ	1100	Anti Dive 47E	84-86	<b>MCG 557 Y</b>		<b>MCH 33</b>							
FJ	1200	1XJ	86-87	<b>MCG 557 Y</b>		<b>MCH 33</b>							
FJ	1200	3CW	88-90	<b>MCG 557 Y</b>		<b>MCH 57</b>	<b>MCH 21</b>	<b>MCH 96</b>					
FJ	1200	3YA	91-94	<b>MCG 557 Y</b>		<b>MCH 64</b>	<b>MCH 65</b>	<b>MCH 96</b>					
FJ	1200	mit ABS 3YA	91-94	<b>MCG 557 Y</b>				<b>MCH 96</b>					
XJR	1200	4 PU	94-	<b>MCG 558 Y</b>			<b>MCH 58</b>	<b>MCH 95</b>					
XJR	1300	RP02/RP06	99-	<b>MCG 558 Y</b>			<b>MCH 58</b>	<b>MCH 95</b>					

1) Verkleidungsänderung nötig

2) kürzere Scheibe nötig

3) Lenkerempfehlung: MCL 128

4) 2 x MCZ 531 nötig

5) verlängerter Gaszug

6) auch mit elektr. Lenkungsdämpfer

7) in MCG 611 enthalten

VH+ = inkl. Halter für Tank

1) modification of the panelling necessary

2) smaller windscreen necessary

3) handlebar recommended: MCL 128

4) 2 x MCZ 531 required

5) throttle control cable

6) also with electrical steering damper

7) included in MCG 611

VH+ = fuel tank support

1) modification de carène

2) modification du pare-brise

3) guidon recommandé: MCL 128

4) 2 x MCZ 531 nécessaire

5) pot d'échappement

6) également avec amortisseur de guidon électrique

7) contenu dans le MCG 611

VH+ = support de réservoir inclusive

## Rennsportlenker mit TÜV-Gutachten

*Racing handlebar*

*Bracelets*



MCL 45 EC  
MCL 50 EC

### BLACK EDITION Stummellenker

- hochwertiger Aluminiumlenker für den sportlichen Einsatz
- Höhe der Klemmschelle 32 mm
- Winkel der Lenkrohr-Kröpfung = 5°
- extrem leichtgewichtig mit nur 660 g
- schwarz eloxiert, Lenkrohrstopfen inklusive
- Ausführung der Klemmschelle in 45 und 50 mm Durchmesser
- Anwendung bei anderen Gabeldurchmessern mittels Distanzhülsen (siehe S. 2.24)

### BLACK EDITION Handle bars

- high-grade aluminium handle bars for motor sport
- height of the clamp 32 mm
- angle of the handle bar tube bend = 5°
- extremely light-weight at only 660 g
- anodised black, including handle bar tube end bungs
- 45 and 50 mm diameter clamp versions
- use with other fork diameters using spacer sleeves (see page 2.24)

### BLACK EDITION Guidon bracelet

- guidon en aluminium de qualité supérieure pour le sport
- hauteur du collier de serrage 32 mm
- angle du coude du guidon = 5°
- extrêmement léger avec seulement 660 g
- anodisé noir, y compris embouts pour guidon
- modèles de collier de serrage en 45 et 50 mm de diamètre
- utilisation pour d'autres diamètres de fourche au moyen de douilles de distance (voir p. 2.24)



**NEU!**  
**NEW!**  
**NOUVEAU!**

**Stahlflexbrems-/Kupplungsleitungen in Schwarz**  
*Steelflex brake-/clutch lines in black*  
*Conduites de frein en flexible acier/conduites d'embrayage en noir*

**Mit TÜV-Gutachten, kein Eintrag im Schein oder Brief nötig!**

**Mehr über Stahlflexleitungen siehe Kapitel 6**  
*For more information on steelflex lines see chapter 6*  
*Pour plus d'informations sur les conduites en flexible acier voir le chapitre 6*



**MCZ 531 S**

**Minibehälter, Aluminium**  
*Mini style fluid reservoir, aluminium*  
*Réservoir de liquide, aluminium*



## Ducati

750/900	SS	S	91-94	50	<b>MCL 50 EC</b>	
888		888 S	93-	50	<b>MCL 50 EC</b>	

## Honda

CBR	600	F	PC25/ PC31	91-98	41	<b>MCL 45 EC</b>	<b>MCL 41 DH</b>
CBR	600	F	PC35	99-	43	<b>MCL 45 EC</b>	<b>MCL 43 DH</b>
CBR	600	RR	PC37	03-04	45	<b>MCL 45 EC</b>	
CBR	600	RR	PC37/PC40	05-	50	<b>MCL 50 EC</b>	
VFR	800		RC46	98-01	41	<b>MCL 45 EC</b>	<b>MCL 41 DH</b>
VFR	800		RC46	02-	43	<b>MCL 45 EC</b>	<b>MCL 43 DH</b>
CBR	900	RR	SC28/SC33	92-99	45	<b>MCL 45 EC</b>	
CBR	900	RR	SC44/SC50	00-03	50	<b>MCL 50 EC</b>	
CBR	1000	Fireblade	SC57	04-	50	<b>MCL 50 EC</b>	
CBR	1000	F Dual	SC24	93-	41	<b>MCL 45 EC</b>	<b>MCL 41 DH</b>
VTR	1000	Firestorm	SC36	96-	41	<b>MCL 45 EC</b>	<b>MCL 41 DH</b>
VTR	1000	SP1/ SP2	SC45	00-	50	<b>MCL 50 EC</b>	
CBR	1100	XX	SC35	96-	43	<b>MCL 45 EC</b>	<b>MCL 43 DH</b>

## Kawasaki

ZXR	400		ZX400L	91-01	50	<b>MCL 50 EC</b>	
ZX-6R	600	Ninja	ZX600F	94-97	41	<b>MCL 45 EC</b>	<b>MCL 41 DH</b>
ZX-6R	600	Ninja	ZX600G/J	98-02	46	<b>MCL 50 EC</b>	<b>MCL 46 DH</b>
ZX-6RR	600		ZX600K/N	03-06	50	<b>MCL 50 EC</b>	
ZX-6R	600	Ninja	ZX600P	07-	50	<b>MCL 50 EC</b>	
ZX-6R	636	Ninja	ZX636A	02	46	<b>MCL 50 EC</b>	<b>MCL 46 DH</b>
ZX-6R	636	Ninja	ZX636B	03-06	50	<b>MCL 50 EC</b>	
ZX-9R	900	Ninja	ZX900C/E	98-03	46	<b>MCL 50 EC</b>	<b>MCL 46 DH</b>
ZX-10R	1000	Ninja	ZXT00C/D	04-	50	<b>MCL 50 EC</b>	
ZZR	1100		ZXT10D	94-01	43	<b>MCL 45 EC</b>	<b>MCL 43 DH</b>
ZZR	1200		ZXT20C	02-	43	<b>MCL 45 EC</b>	<b>MCL 43 DH</b>

## Suzuki

RGV	250		VJ22B	91-	50	<b>MCL 50 EC</b>	
GSXR	600		AD/WVBG	97-03	45	<b>MCL 45 EC</b>	
GSXR	600		WVB2/WVCE	04-	50	<b>MCL 50 EC</b>	
SV	650	S	AV	99-02	41	<b>MCL 45 EC</b>	<b>MCL 41 DH</b>
SV	650	S	WVBY	03-	41	<b>MCL 45 EC</b>	<b>MCL 41 DH</b>
GSXR	750		GR7AB	90-91	50	<b>MCL 50 EC</b>	
GSXR	750	W	GR7BB	92-97	50	<b>MCL 50 EC</b>	
GSXR	750	W	GR7DB	98-99	50	<b>MCL 50 EC</b>	
GSXR	750		WVBD/WVB3	00-05	50	<b>MCL 50 EC</b>	
GSXR	750		WVCF	06-	50	<b>MCL 50 EC</b>	
RF	900		GT73B	94-97	43	<b>MCL 45 EC</b>	<b>MCL 43 DH</b>
GSXR	1000		WVBL/WVBZ	01-04	50	<b>MCL 50 EC</b>	
GSXR	1000		WVB6/WVCL	05-	50	<b>MCL 50 EC</b>	
SV	1000	S	WVBX	03-	46	<b>MCL 50 EC</b>	<b>MCL 46 DH</b>
TL	1000	S/R	AG/AM	97-	50	<b>MCL 50 EC</b>	
GSXR	1100	W	GU75C	95-96	50	<b>MCL 50 EC</b>	

## Triumph

675	Daytona	D67LC	06-	50	<b>MCL 50 EC</b>	
900	Speed Triple	T300B/T509	94-00	43	<b>MCL 45 EC</b>	<b>MCL 43 DH</b>
900	Thruxton	986ME	04-	41	<b>MCL 45 EC</b>	<b>MCL 41 DH</b>
955	Daytona	T595	96-	45	<b>MCL 45 EC</b>	
1000	Daytona	T300	91-	43	<b>MCL 45 EC</b>	<b>MCL 43 DH</b>
1200	Daytona	T300	93-	43	<b>MCL 45 EC</b>	<b>MCL 43 DH</b>

## Yamaha

FZR	600		3HE/3RG/3RH	89-93	41	<b>MCL 45 EC</b>	<b>MCL 41 DH</b>
FZR	600	R	4JH/4MH	94-95	41	<b>MCL 45 EC</b>	<b>MCL 41 DH</b>
YZF	600	Thunder Cat	4TV	96-	41	<b>MCL 45 EC</b>	<b>MCL 41 DH</b>
YZF	600	R6	RJ03/RJ05	99-04	43	<b>MCL 45 EC</b>	<b>MCL 43 DH</b>
YZF	600	R6	RJ09	05	43	<b>MCL 45 EC</b>	<b>MCL 43 DH</b>
YZF	600	R6	RJ11	06-	50	<b>MCL 50 EC *</b>	
YZF	750	R, SP	4HN/4HT	93-96	50	<b>MCL 50 EC</b>	
TRX	850		4UN	96-	41	<b>MCL 45 EC</b>	<b>MCL 41 DH</b>
FZR	1000	ex up	3LE	89-90	43	<b>MCL 45 EC</b>	<b>MCL 43 DH</b>
FZR	1000	up side d.	3LE	91-95	50	<b>MCL 50 EC</b>	
YZF	1000	Thunder Ace	4VD	96-	48	<b>MCL 50 EC</b>	<b>MCL 48 DH</b>
YZF	1000	R1	RN01/RN04	98-01	50	<b>MCL 50 EC</b>	
YZF	1000	R1	RN09/RN12	02-05	50	<b>MCL 50 EC</b>	
YZF	1000	R1	RN19	06-	50	<b>MCL 50 EC *</b>	
FJ	1200	A	3YA	90-94	41	<b>MCL 45 EC</b>	<b>MCL 41 DH</b>

\* ohne Lenkungsdämpferbefestigung without steering damper mount sans fixation de l'amortisseur de guidon

## Bequemer Sportlenker mit TÜV-Gutachten Comfort sport handlebars Bracelets

### Die neue Lenker-Generation **RELAX BAR**

**CNC-gefräster Sportlenker aus Aluminium  
für die bequeme Sitzposition**

- entspannte Griffhaltung, entlastete Handgelenke
- kein Abschneiden der Verkleidung notwendig (siehe empfohlene Zuordnung S. 2.25–2.26)
- passend für viele Motorräder durch die Vielfalt der Distanzhülsen
- Wechsel zurück zum Originalzustand kein Problem
- gefräste Lenkrohraufnahmen in unterschiedlichen Höhen ermöglichen:
  - ▶ auch eine Montage über der Brücke
  - ▶ individuelle Ausrichtung der Sitzposition
  - ▶ bei vielen Modellen ist die Beibehaltung des Verkleidungsoberteils möglich
  - ▶ bis zu ca. 80 mm höhere Griffposition

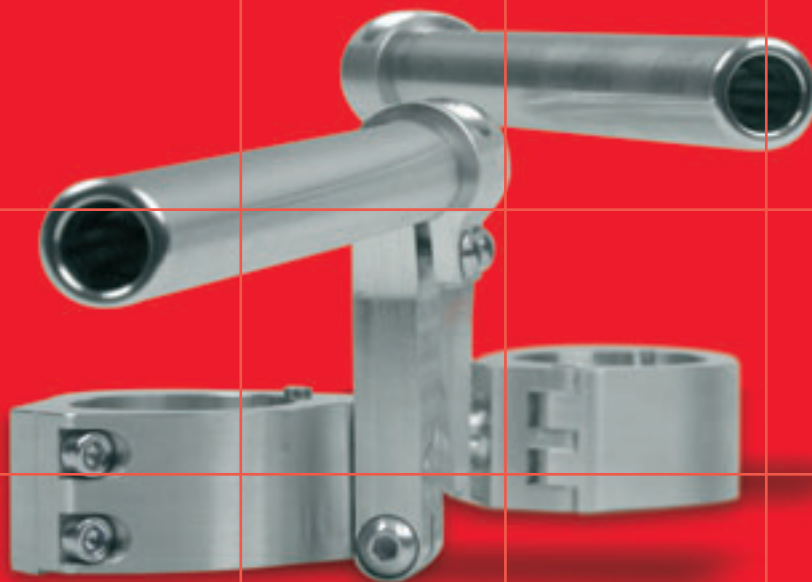

### The new generation of handlebars **RELAX BAR**

*aluminium CNC machined Sport handlebar  
for a comfortable seating position*

- *relaxed grip, reduced pressure on the wrist*
- *no trimming of the panelling necessary (see recommended fitting, page 2.25–2.26)*
- *suitable for a large number of motorcycles due to the wide range of spacers*
- *reverting back to the original setting is no problem*
- *CNC ground risers in various heights make it possible to:*
  - ▶ *fit under or over the triple tree*
  - ▶ *set the riding position to suit the individual*
  - ▶ *retain the original body work with many models*
  - ▶ *grip position can be up to 80mm higher*

### La nouvelle génération de guidons **RELAX BAR**

*guidon sport aluminium usiné CNC pour  
une assise confortable*

- *pression réduite au niveau des poignets*
- *pas de modification de carène nécessaire (voir page 2.25–2.26)*
- *adaptable à un grand nombre de motos grâce à l'utilisation d'une grande gamme d'entretoises*
- *le remontage du Té d'origine est tout à fait possible*
- *les différentes hauteurs de cales de guidons rendent possible:*
  - ▶ *de remonter les demi-guidons par rapport au té*
  - ▶ *d'ajuster la position idéale en fonction du pilote*
  - ▶ *sur de nombreuses motos, il est possible de conserver les composants d'origine*
  - ▶ *la position maximale haute peut se rapprocher de 80 mm*

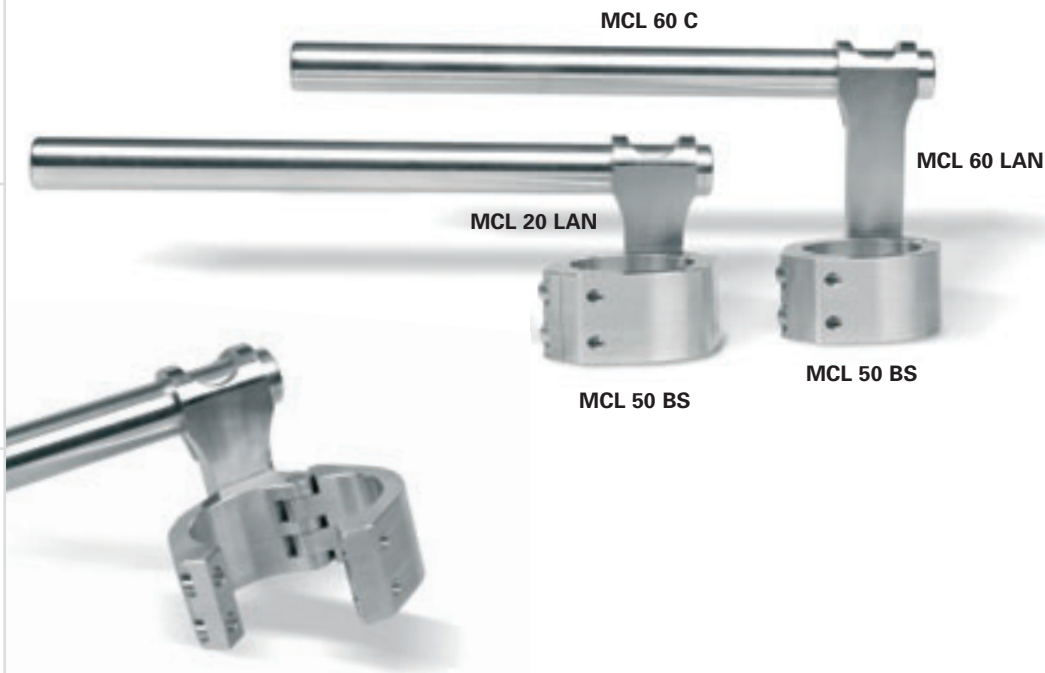

Manche Modelle mit hohen Lenkrohraufnahmen benötigen eine geringe Lenkeinschlagbegrenzung. Verlängerte Brems- und Kupplungsleitungen sind bei kurzen Lenkrohraufnahmen nicht nötig. Bei Bedarf den Flüssigkeitsbehälter verlegen und durch Mini-behälter ersetzen.

*Some models need a reduction of the steering lock angle. Longer brake and clutch cables are not always needed for smaller risers. Where required replace the fluid reservoir with a mini reservoir.*

*Quelques modèles équipés d'un antivol de direction possèdent un angle de braquage plus petit. Il n'est pas nécessaire de rallonger les câbles de frein et d'embrayage pour les motos pourvues d'une petite colonne de direction. Lorsque cela est requis, remplacer le réservoir de liquide par un modèle plus petit.*

- Die Lenkrohre können nach Wunsch im Winkel über und unter 0 Grad verschraubt werden. Eine Skalierung ermöglicht eine leichte Ausrichtung von rechter und linker Seite. Bei einem Durchmesser von 45 und 50 mm entfallen die Distanzhülsen.
- *The handle bars can be angled above or below horizontal as desired. Minor left and right adjustment is possible. Spacer sleeves are not required for fork diameters of 45 and 50 mm.*
- *Les tubes du guidon peuvent être vissés comme souhaité à un angle au dessus ou en dessous de 0. Un cadran permet une légère déviation du côté droit ou gauche. Les douilles de distance sont supprimées avec un diamètre de 45 et 50 mm.*

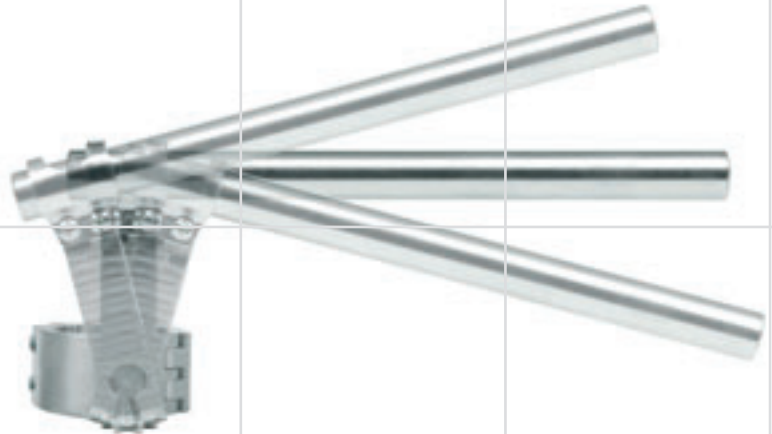

**Mit TÜV-Gutachten, kein Eintrag in Schein oder Brief nötig!**

1 Stück  
1 pièce  
1 pièce



MCL 60 LR



MCL 45 RAC  
MCL 50 RAC  
MCL 53 RAC

**Ersatzlenkrohr Racing-Set (RAC)**  
*Replacement handlebar (RAC)*  
*Demi-guidons de rechange (RAC)*

**Racing-Set ohne Lenkrohraufnahme zum Direktverschrauben**  
*Racing set fitted without handlebar riser*  
*Le kit de racing se monte sans support de différentes hauteurs*

⚡ **Abverkauf**  
*running out*  
*vente à part*

# Bequemer Sportlenker mit TÜV-Gutachten

## Comfort sport handlebars

### Bracelets



2 Stück  
2 pieces  
2 pièces

MCL 45 BS  
MCL 50 BS



2 Stück  
2 pieces  
2 pièces

MCL 20 LAN (20 mm)  
MCL 40 LAN (40 mm)  
MCL 60 LAN (60 mm)

**Basis-Set besteht aus 2 Klemmschellen in 50 mm oder 45 mm Durchmesser. Das Set ist nur mit Lenkrohraufnahme montierbar.**

*The basic set consists of 2 clamps with either a 50 mm or 45 mm diameter. The set can only be mounted with a handlebar column holder.*

*Le kit de base est composé de deux fixations principales que ce soit le diamètre 45 mm ou 50 mm. Le kit peut être monté avec des câles de différentes hauteurs selon les besoins.*

**Lenkrohraufnahmen in 3 verschiedenen Höhen**

*Risers in 3 various heights must be ordered separately*

*Les câles existent en 3 hauteurs et doivent être commandées séparément*

**Bestellbeispiel RELAX BAR:**

1 x Basis-Set (MCL 50 BS)  
1 x Lenkrohraufnahme (MCL 40 LAN)  
1 x Lenkrohrsatz (MCL 60 C)

**bei Bedarf:**

1 x Distanzhülse (MCL 48 DH)

**Ordering example RELAX BAR:**

1 x Basic set (MCL 50 BS)  
1 x Risers (MCL 40 LAN)  
1 x Handlebars (MCL 60 C)

**if necessary:**

1 x Spacer sleeves (MCL 48 DH)

**Exemple de commande RELAX BAR:**

1 x Kit de base (MCL 50 BS)  
1 x Cales (MCL 40 LAN)  
1 x Tubes du guidon (MCL 60 C)

**selon les besoins:**

1 x Entretoises (MCL 48 DH)



2 Stück  
2 pieces  
2 pièces

MCL 60 C  
MCL 60 B  
MCL 60 S



2 Stück  
2 pieces  
2 pièces

MCL 38 DH  
MCL 41 DH  
MCL 43 DH  
MCL 46 DH  
MCL 48 DH  
MCL 52 DH

**Eloxierte Lenkrohre**  
*Anodized handlebars*  
*Demis guidons de rechange anodisés*

**C** silber  
silver  
argent  
**B** blau  
blue  
bleu  
**S** schwarz  
black  
noir

**Distanzhülsen für verschiedene Lenkrohrdurchmesser**

*Spacer sleeves for the required handlebar to fit the diameter of your handlebar column*  
*Pour certaines motos il faut commander ces entretoises afin de monter le kit de base*



MCL 310

MCL 300

**Lenkrohrstopfen aus Alu oder Teflon**  
*Handlebar stoppers teflon or aluminium*  
*Embouts guidon téflon ou aluminium*

2 Stück  
2 pieces  
2 pièces



### Aprilia

RSV	1000	Mille	ME	98-00	53	MCL 53 RAC
RSV	1000	Mille	RP	01-03	53	MCL 53 RAC
RSV	1000	R	RR	04-	53	MCL 53 RAC

### Ducati

748				94-03	53	MCL 53 RAC
750	SS	S		93-94	50	MCL 50 BS
888				93-	50	MCL 50 BS
900	SS	S		91-	50	MCL 50 BS
916				94-98	53	MCL 53 RAC
996				99-	53	MCL 53 RAC
998				01-	53	MCL 53 RAC
999				03-	53	MCL 53 RAC

### Honda

CBR	600	F	PC25	91-94	41	MCL 45 BS	MCL 41 DH	MCL 40 LAN	MCL 60 LAN <sup>1)</sup>
CBR	600	F	PC31	95-98	41	MCL 45 BS	MCL 41 DH	MCL 40 LAN	MCL 60 LAN <sup>1)</sup>
CBR	600	F	PC35	99-	43	MCL 45 BS	MCL 43 DH	MCL 40 LAN	MCL 60 LAN <sup>1)</sup>
CBR	600	RR	PC37	03-04	45	MCL 45 RAC	MCL 45 BS	MCL 20 LAN	
CBR	600	RR	PC37	05-	48	MCL 50 RAC	MCL 50 BS	MCL 48 DH	MCL 20 LAN
VFR	800		RC46	98-	41	MCL 45 RAC	MCL 45 BS	MCL 41 DH	MCL 20 LAN
VFR	800		RC46	02-	43	MCL 45 RAC		MCL 43 DH	
CBR	900	RR	SC28	92-95	45	MCL 45 RAC	MCL 45 BS	MCL 20 LAN	MCL 60 LAN <sup>1)</sup>
CBR	900	RR	SC33	96-99	45	MCL 45 RAC	MCL 45 BS	MCL 20 LAN	MCL 60 LAN <sup>1)</sup>
CBR	900	RR	SC44	00-01	50	MCL 50 RAC	MCL 50 BS	MCL 20 LAN	
CBR	900	RR	SC50	02-03	50	MCL 50 RAC	MCL 50 BS	MCL 20 LAN	
CBR	1000	Fireblade	SC57	04-	50	MCL 50 RAC	MCL 50 BS	MCL 20 LAN	
CBR	1000	F Dual	SC24	93-	41		MCL 45 BS	MCL 41 DH	MCL 40 LAN
VTR	1000	Firestorm	SC36	96-	41		MCL 45 BS	MCL 41 DH	MCL 20 LAN
VTR	1000	SP1	SC45	00-01	50	MCL 50 RAC	MCL 50 BS	MCL 20 LAN	
VTR	1000	SP2	SC45	02-	50	MCL 50 RAC	MCL 50 BS	MCL 20 LAN	
CBR	1100	XX	SC35	96-	43		MCL 45 BS	MCL 43 DH	MCL 40 LAN

### Kawasaki

ZXR	400		ZX400L	91-01	50	MCL 50 RAC	MCL 50 BS	MCL 20 LAN	
ZX-6R	600	Ninja	ZX600F	94-97	41		MCL 45 BS	MCL 41 DH	MCL 20 LAN
ZX-6R	600	Ninja	ZX600G/H	98-01	46		MCL 50 BS	MCL 46 DH	MCL 20 LAN
ZX-6R	600	RR	ZX600K/N	03-	50	MCL 50 RAC	MCL 50 BS	MCL 20 LAN	MCL 40 LAN
ZX-6R	636	Ninja	ZX636A	02	46		MCL 50 BS	MCL 46 DH	MCL 20 LAN
ZX-6R	636	Ninja	ZX636B/C	03-	50	MCL 50 RAC	MCL 50 BS	MCL 20 LAN	
ZX-7R	750	Ninja	ZX750P	95-	52	MCL 53 RAC		MCL 52 DH	
ZXR	750		ZX750K/L	92-	52	MCL 53 RAC		MCL 52 DH	
ZXR	750		ZX750M	93-95	52	MCL 53 RAC		MCL 52 DH	
ZX-9R	900	Ninja	ZX900B	94-97	52	MCL 53 RAC		MCL 52 DH	
ZX-9R	900	Ninja	ZX900C/D	98-00	46		MCL 50 BS	MCL 46 DH	MCL 20 LAN
ZX-9R	900	Ninja	ZX900E	01-	46		MCL 50 BS	MCL 46 DH	MCL 20 LAN
ZX-10R	1000	Ninja	ZX1000C	04-	50	MCL 50 RAC	MCL 50 BS	MCL 20 LAN	
ZZR	1100		ZXT10D	94-01	43		MCL 45 BS	MCL 43 DH	MCL 40 LAN
ZZR	1200		ZXT20C	02-	43		MCL 45 BS	MCL 43 DH	MCL 40 LAN

### Suzuki

RGV	250		VJ22B	91-	50	MCL 50 RAC	MCL 50 BS	MCL 20 LAN	
GSXR	600		AD311	97-03	45	MCL 45 RAC	MCL 45 BS	MCL 20 LAN	MCL 40 LAN
GSXR	600		WVB2	04-05	50	MCL 50 RAC	MCL 50 BS	MCL 20 LAN	
GSXR	600		CE	06-	50	MCL 50 RAC	MCL 50 BS	MCL 20 LAN	
SV	650	S	AV111	99-02	41		MCL 45 BS	MCL 41 DH	MCL 20 LAN
SV	650	S	WVBY	03-	41		MCL 45 BS	MCL 41 DH	MCL 20 LAN
GSXR	750		GR7AB	90-91	50	MCL 50 RAC	MCL 50 BS	MCL 40 LAN	MCL 60 LAN
GSXR	750	W	GR7BB	92-97	50	MCL 50 RAC	MCL 50 BS	MCL 40 LAN	MCL 60 LAN
GSXR	750	W	GR7DB	98-99	50	MCL 50 RAC	MCL 50 BS	MCL 20 LAN	MCL 40 LAN
GSXR	750		WVBD	00-03	50	MCL 50 RAC	MCL 50 BS	MCL 20 LAN	MCL 40 LAN
GSXR	750		WVB3	04-05	50	MCL 50 RAC	MCL 50 BS	MCL 20 LAN	
GSXR	750		CF	06-	50	MCL 50 RAC	MCL 50 BS	MCL 20 LAN	
RF	900		GT73B	94-97	43		MCL 45 BS	MCL 43 DH	MCL 20 LAN
GSXR	1000		WVBL	01-02	50	MCL 50 RAC	MCL 50 BS	MCL 20 LAN	MCL 40 LAN
GSXR	1000		WVBZ	03-04	50	MCL 50 RAC	MCL 50 BS	MCL 20 LAN	MCL 40 LAN
GSXR	1000		WMB6	05-	50	MCL 50 RAC	MCL 50 BS	MCL 20 LAN	MCL 40 LAN
SV	1000	S	WVBX	03-	46		MCL 50 BS	MCL 46 DH	MCL 60 LAN
TL	1000	S	AG111	97	50	MCL 50 RAC	MCL 50 BS <sup>2)</sup>	MCL 20 LAN	
TL	1000	R	AM321	98-	50	MCL 50 RAC	MCL 50 BS <sup>2)</sup>	MCL 20 LAN	
GSXR	1100		GV73C	90-92	52	MCL 53 RAC		MCL 52 DH	
GSXR	1100	W	GU75C	93-94	52	MCL 53 RAC		MCL 52 DH	
GSXR	1100	W	GU75C	95-96	50	MCL 50 RAC	MCL 50 BS	MCL 40 LAN	MCL 60 LAN



## Triumph

900	Speed Triple		94-95	43		<b>MCL 45 BS</b>	<b>MCL 43 DH</b>	<b>MCL 20 LAN</b>	<b>MCL 40 LAN</b>	
900	Speed Triple T509		96-	43		<b>MCL 45 BS</b>	<b>MCL 43 DH</b>	<b>MCL 20 LAN</b>	<b>MCL 40 LAN</b>	
955	Daytona T595		96-	45	<b>MCL 45 RAC</b>	<b>MCL 45 BS</b>		<b>MCL 20 LAN</b>	<b>MCL 40 LAN</b>	
1000/1200	Daytona T300		91-	43		<b>MCL 45 BS</b>	<b>MCL 43 DH</b>	<b>MCL 20 LAN</b>	<b>MCL 40 LAN</b>	

## Yamaha

FZR	600	3HE/3RG	89-93	41		<b>MCL 45 BS</b>	<b>MCL 41 DH</b>	<b>MCL 20 LAN</b>	<b>MCL 40 LAN</b>	
FZR	600	3RH	89-93	41		<b>MCL 45 BS</b>	<b>MCL 41 DH</b>	<b>MCL 20 LAN</b>	<b>MCL 40 LAN</b>	
FZR	600	R 4JH/4MH	94-95	41		<b>MCL 45 BS</b>	<b>MCL 41 DH</b>	<b>MCL 20 LAN</b>	<b>MCL 40 LAN</b>	
YZF	600	Thunder Cat 4TV	96-	41		<b>MCL 45 BS</b>	<b>MCL 41 DH</b>	<b>MCL 20 LAN</b>		
YZF	600	R6 RJ03	99-02	43		<b>MCL 45 BS</b>	<b>MCL 43 DH</b>	<b>MCL 20 LAN</b>		
YZF	600	R6 RJ05	03-04	43		<b>MCL 45 BS</b>	<b>MCL 43 DH</b>	<b>MCL 20 LAN</b>		
YZF	600	R6 RJ09	05	50		<b>MCL 50 BS</b>		<b>MCL 20 LAN</b>		
YZF	750	R 4HN	93-96	50	<b>MCL 50 RAC</b>	<b>MCL 50 BS</b>		<b>MCL 20 LAN</b>		
YZF	750	SP 4HT	95-96	50	<b>MCL 50 RAC</b>	<b>MCL 50 BS</b>		<b>MCL 20 LAN</b>		
TRX	850	4UN	96-	41		<b>MCL 45 BS</b>	<b>MCL 41 DH</b>		<b>MCL 40 LAN</b>	
FZR	1000	ex up 3LE	89-90	43		<b>MCL 45 BS<sup>3)</sup></b>	<b>MCL 43 DH</b>	<b>MCL 20 LAN</b>	<b>MCL 40 LAN</b>	<b>MCL 60 LAN</b>
FZR	1000	up side d. 3LE	91-95	50	<b>MCL 50 RAC</b>	<b>MCL 50 BS<sup>3)</sup></b>		<b>MCL 20 LAN</b>	<b>MCL 40 LAN</b>	<b>MCL 60 LAN</b>
YZF	1000	Thunder Ace 4VD	96-	48		<b>MCL 50 BS</b>	<b>MCL 48 DH</b>	<b>MCL 20 LAN</b>		
YZF	1000	R1 RN01	98-00	50	<b>MCL 50 RAC</b>	<b>MCL 50 BS</b>		<b>MCL 20 LAN</b>		
YZF	1000	R1 RN04	01	50	<b>MCL 50 RAC</b>	<b>MCL 50 BS</b>		<b>MCL 20 LAN</b>		
YZF	1000	R1 RN09	02-03	50	<b>MCL 50 RAC</b>	<b>MCL 50 BS</b>		<b>MCL 20 LAN</b>		
YZF	1000	R1 RN12	04-05	50	<b>MCL 50 RAC</b>	<b>MCL 50 BS</b>		<b>MCL 20 LAN</b>		
FJ	1200	A 3YA	90-94	41		<b>MCL 45 BS</b>	<b>MCL 41 DH</b>	<b>MCL 20 LAN</b>		

- 1) unter Gabelbrücke montiert
- 2) nur ohne Lenkungsdämpfer
- 3) Verkleidung kürzen notwendig

- 1) mounted below the top yoke
- 2) only without steering damper
- 3) panel modification necessary

- 1) monté sous le pont de la fourche
- 2) uniquement sans amortisseur de guidon
- 3) raccourcit le carénage

